

"WE CONTROL THE FLOW"

**BALL
VALVES**





Table Of Contents

➤ Company Introduction	01
➤ Design Job	02
➤ Quality Control	03
➤ Raw Material Inspection	04
➤ Production	05
➤ Valve Testing	06
➤ Product Range	07
➤ Ball Valve Type & Features	08
➤ Floating Type(1PC)	10
➤ Floating Type(2PC)	11
➤ Floating Type(3PC)	12
➤ Floating Ball Valve Dimension & Weights	13
➤ Trunnion Type(Casting)	16
➤ Trunnion Type(Forged)	17
➤ Trunnion Ball Valve Dimension & Weights	19
➤ Top Entry Ball Valve	28
➤ Fully Welded Trunnion & Extended Stem Ball Valve	30
➤ Three-Way Ball Valve	31
➤ Double Block And Bleed Ball Valve	32
➤ Seat & Seal Design Features	34
➤ Valve Operation/Gear & Actuator Details	35
➤ Painting & Packing	36
➤ How To Avoid Problems	37

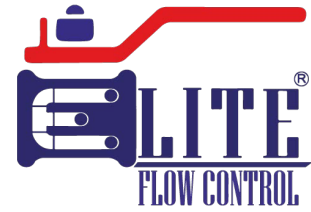

Profile:

Elite Flow Control is one of the leading and renowned brand of Valves having its own independent manufacturing facilities and global existence.

Our design and manufacturing range includes Ball Valves, Gate Valves, Globe Valves, Check Valves, Plug Valves, Butterfly Valves, Control Valves, Actuated Valves, and have a dedicated PTFE / PFA lining facility for PTFE / PFA Lined Valves, Pipe Spools, Pipe fittings, and associated equipment for high corrosive/chemical applications.

The material of construction capabilities includes but not limited to Carbon Steel, Stainless Steel, Alloy Steel, Duplex Steel, Super Duplex, Monel, Titanium, Hastelloy and each valve is manufactured in accordance with its applicable manufacturing standard such as ISO, API, PED / CE, BS 1873, BS 1868, MSS SP-67, MSS SP-68, ASME and Fire Safe Design in API 607 / API 6FA.

We have stringent Quality Management and Control System backed by qualification of ISO 9001:2015, PED (Pressure Equipment Directive), API 6D, API 607, API 6FA, SIL (Functional Safety Certificate), and our strong commitment to Environmental Management System, and Occupational Health and Safety Management Systems (OHSMS) is accredited with 14001:2015 and ISO 45001:2018 certification.

Mission:

Elite Flow Control focused to provide the superior quality valves at competitive prices to its customers around the world by utilizing the company's human resources and advanced technology equipment with the strong commitment to R&D, Health, Safety, Environment and company's core values.

Vision:

To make our brand "the first choice of customers".

Core Values:

Quality: It is our primary focus to produce and deliver superior quality products.

Commitment: What we commit, We deliver.

Team Work: We believe on team work which is the most important element to accomplish the set objective.

Customer Satisfaction: To achieve customer satisfaction with our Quality, Commitment and Team Work.



Design Job:

Elite Valves are manufactured as per international standards such as API, ANSI, ASME, ASTM, MSS, NACE. Our engineering team consistently monitors update to these standards and incorporates any applicable changes that affect the design, regulations and performance of our valves. Each steps of valve engineering and manufacturing can be validated using advance software starting from 3D model to finite element analysis of loads, tension and deformations and final stress test.

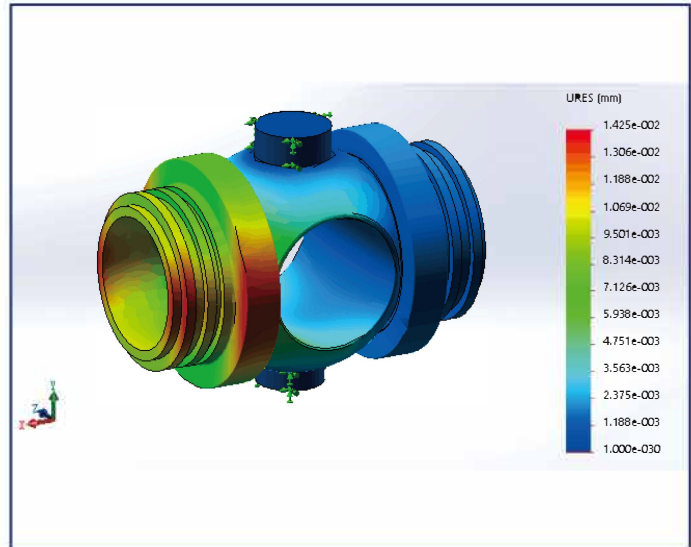

Finite Element Analysis

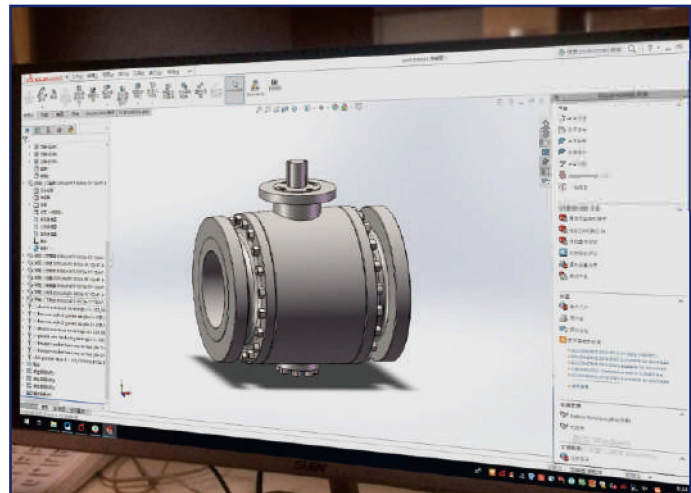

3D Model Design

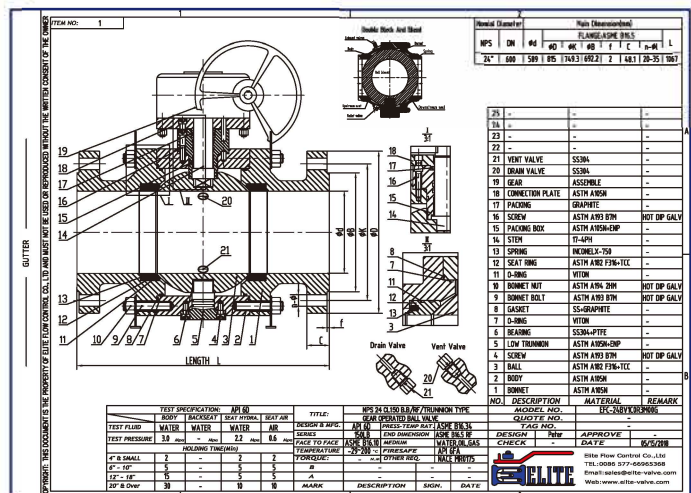

Typical Valve Drawing

Quality Control:

Our Quality Management System (QMS) is very well established under supervision of various teams of qualified and certified Engineers in strict compliance with international recognized quality standards such as ISO 9001, CE, PED, API 6D, API 600 etc.

Elite Flow Control guarantees the performance and reliability of its products through the systematic 100% testing & Inspection.

All the tests are done internally in the dedicated testing area, by means of multiple and specifically designed (and certified) test benches that are used to control the output of the production line.

Quality is the one of Core Value of the Company and it complied but not limited to the following as minimum:

- Design Review
- Continuous Research for new materials either for construction and for sealing
- Material Properties Control (mechanical and chemical)
- Materials Quality (Volumetric Tests, Magnetic Test, Penetrate Test, PMI)
- Traceability of the materials and parts
- Inspection During Production Process in all its phases
- Performances of the Valves
- Accuracy in the final stage before shipment
- Issuing of complete documentation file in full compliance of project requirement
- Respect of the Contractual Delivery



Raw Material Inspection:

Raw material quality is vital for valve quality, Elite Valve source casting and forging from selected vendor. Before machining, we will take 4 steps to guarantee the material quality.

- 1) Visual Test: Visual test as per MSS SP55, casting with obvious defects will be declined.
- 2) Valve wall thickness test: Random inspection on valve wall thickness by ultrasonic thickness meter , unqualified ones will be declined.
- 3) Chemical Component analysis: Random PMI test is performed to ensure qualification.
- 4) Dimension Check face to face; flange thickness will be check before process.



Forging



Casting



Forged Stock



PMI Inspection

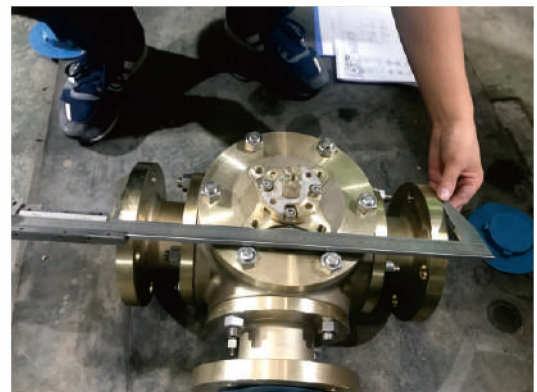

Dimension Check

Production:

When the designs are approved by the customer, the production process starts. Our highly qualified staff works with high speed machines to produce valves accordingly as per requirement. After rough machining, 20% of valve component is checked dimensionally by Q.C inspectors and 100% after fine machining.



Machine Center



Engine Lathe



Assembling



End Product



Dimension Check

Valve Testing :

After the production process has finished 100% of valves are tested in-house. Our valves have to ensure a hydro-test on body and seat, followed by a low pressure air-test in excess of API 6D and API 598 requirements. Prior to shipping, additional tests on valves and materials can also be arranged by Elite Valves.

The following standard performance test are performed according to API 6D, API 598 or to customer specific requirements:

- Visual & Dimensional Check
- Hydrostatic Testing
- Low Pressure Gas Seat Testing
- High Pressure Gas Testing
- Cryogenic Gas Testing Down To
-196 °C (-320,8 ° F)
- High Temperature Testing Up To
660°C(1220 ° F)
- Fugitive Emission Gas Testing
- Antistatic Testing
- Torque Testing
- Cavity Relief Testing
- Double Block & Bleed (DBB) Testing
- Double Isolation & Bleed
(DIB-1,DIB-2) Testing

Non –destructive testing (NDT)

The following tests can be performed by 2nd level EN473-SIO9712/SN-TC-1A qualified personal or 3rd party appointed by client.

- VT (Visual testing)
- UT (Ultrasonic testing)
- PT (Penetrant testing)
- MT (Magnetic particle testing)
- LT (Leak testing)
- PMI (Positive Material Identification)
- Hardness test
- Ferrite Test



Cryogenic Testing



Hydrostatic Testing Picture



Pressure Test



Firesafe Test Hartmann



Fugitive Emission Gas testing



Visual Inspection



Ultrasonic Testing



PMI

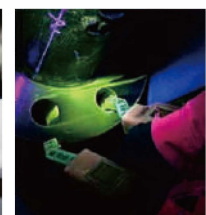

Magnetic Particle Testing

PRODUCT RANGE

SIDE-ENTRY FLOATING BALL VALVE(1PC, 2PC, 3PC)

SERVICE	CL150~600	CL900	CL1500	CL2500
STANDARD	1/2"~6"	1/2"~2"	1/2"~2"	1/2"~1"
LOW TEMP. DOWN TO -196°C	1/2"~4"	1/2"~2"	1/2"~2"	1/2"~1"
UNDERGROUND	1/2"~4"	1/2"~2"	1/2"~2"	1/2"~1"
HIGH TEMP. +200°C TO 425°C	1/2"~4"	1/2"~2"	1/2"~2"	1/2"~1"

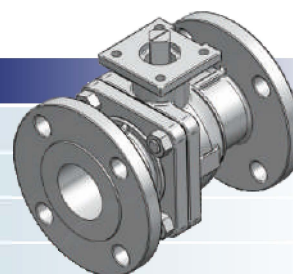

SIDE-ENTRY TRUNNION BALL VALVE

SERVICE	CL150~600	CL900	CL1500	CL2500
STANDARD	2"~48"	2"~48"	2"~24"	2"~12"
LOW TEMP. DOWN TO -196°C	2"~48"	2"~48"	2"~24"	2"~12"
UNDERGROUND	2"~48"	2"~48"	2"~24"	2"~12"
HIGH TEMP. +200°C TO 425°C	2"~48"	2"~48"	2"~24"	2"~12"

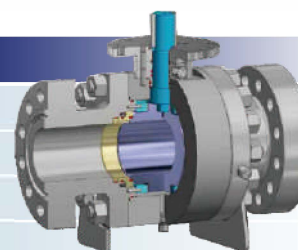

TOP-ENTRY TRUNNION BALL VALVE

SERVICE	CL150~600	CL900	CL1500	CL2500
STANDARD	2"~36"	2"~24"	2"~24"	2"~12"
LOW TEMP. DOWN TO -196°C	2"~36"	2"~24"	2"~24"	2"~12"
UNDERGROUND	2"~36"	2"~24"	2"~24"	2"~12"
HIGH TEMP. +200°C TO 425°C	2"~24"	2"~24"	2"~24"	2"~12"

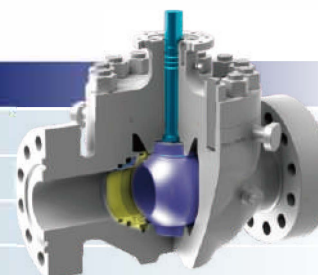

FULLY-WELDED TRUNNION BALL VALVE & EXTENDED SERVICE LIFE

SERVICE	CL150~600	CL900	CL1500	CL2500
STANDARD	2"~48"	2"~48"	2"~24"	2"~12"
LOW TEMP. DOWN TO -196°C	2"~48"	2"~48"	2"~24"	2"~12"
UNDERGROUND	2"~48"	2"~48"	2"~24"	2"~12"
HIGH TEMP. +200°C TO 425°C	2"~48"	2"~48"	2"~24"	2"~12"



APPLICABLE DESIGN STANDARDS

DESIGN	BODY THICKNESS	BOLTING	FACE-TO-FACE	DRIVE TRAIN SIZE	FIRESAFE
API 6D API 608	ASME B16.34 ASME VIII	ASME B16.34 ASME VIII	ASME API 6D ASME B16.10	ASME API 6D	API 607 API 6FA

OTHERS

Materials: ASME II-D, ASTM, API
Flanges: ASME B16.5, ASME B16.47
NDT: ASME, ASTM

Welding: ASME IX
Welding ends: ASME B16.25
Sour service: NACE MR0175, NACE MR0103

BALL VALVE TYPE & FEATURES

Double Block and Bleed (DBB)

- In closed position, blocks flow from both valve ends when the cavity between the seating surfaces is vented through a bleed connection provided on the body cavity.
- Pressure is released in the direction of low pressure.

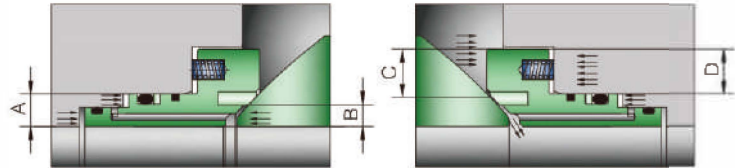

Area (A) > Area (B)
Upstream Seat Seal

Area (C) > Area (D)
Low Pressure Seat Self-relief

Double Isolation and Bleed (DIB)

- Cavity pressure acts on both up stream and downstream seats to create a "Double piston" effect on seat rings that enhances sealing.
- Valves with Double Piston seats require an external cavity relief mechanism while handling non-compressible fluids.

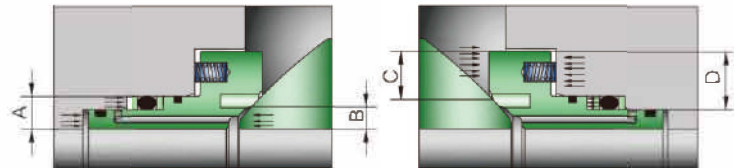

Area (A) > Area (B)
Upstream Seat Seal

Area (C) < Area (D)
Downstream Seat Seal

Emergency Stem Sealing

- This feature is standard for trunnion ball valve.
- Designed to prevent stem leakage under live pipeline pressure.

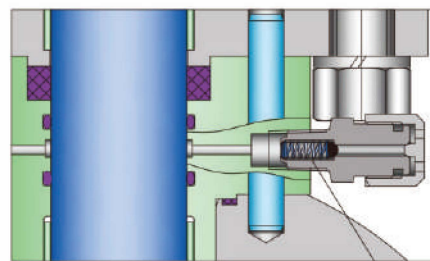

Emergency Seat Sealing

- This feature is standard for trunnion ball valve.
- For 6" and greater it is supplied with seat sealant.
- Prevent and repairs seat leakages, hence eliminates valve failures.
- It acts as secondary sealing of the valve at emergency cases.

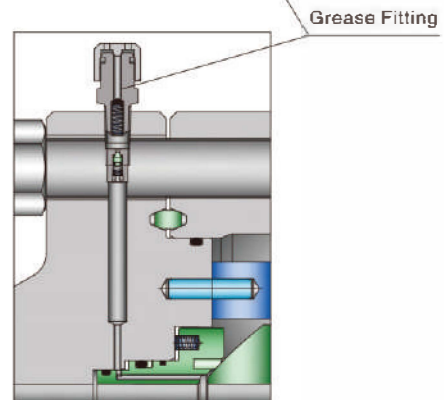

BALL VALVE TYPE & FEATURES

Vent & Drain Facility

- Each valve is supplied with an Anti-Blowout design vent valve and plugged drain connection according to ASME B16.34 / API 6D located at the upper and lower part of the body.
- As standard, vent & drain connections are NPT thread.
- Alternative vent & drain designs incorporating fully welded flange or a pad type flange connection fitted with blind flange with gate or ball valve are available.

VENT & DRAIN VALVE

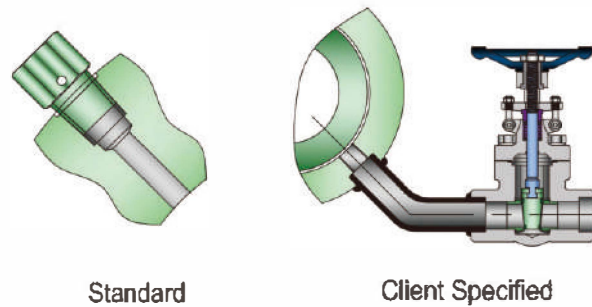

Blowout-Proof Stem

- The stem is designed with integral T-type shoulder to provide blow-out proof effectively.

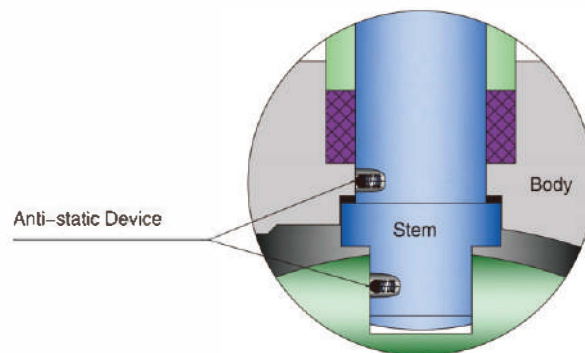

Anti-Static Device

- A spring loaded grounding ball ensures the electrical continuity between the Ball, Stem and Body to avoid sparks during the opening and closing of the valves.

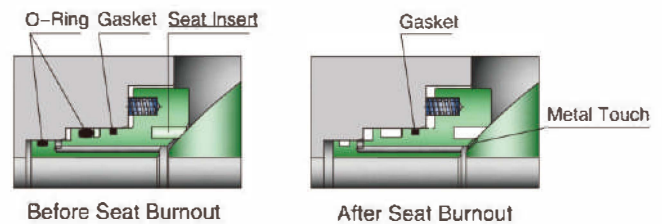

Fire Safe Design

- Ball valve are fire-safe by design and meet the requirements of API 607 and API 6FA.
- The gaskets and stem seals are long lasting and resistant to high temperature.

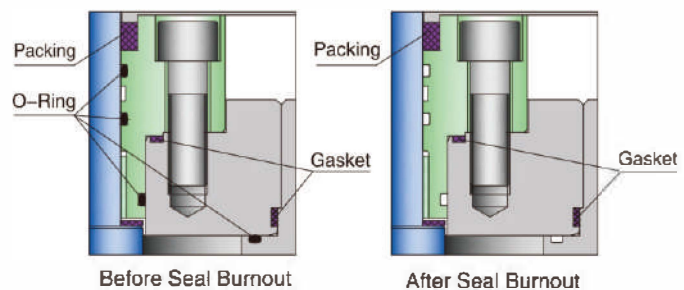

FLOATING TYPE (1PC)

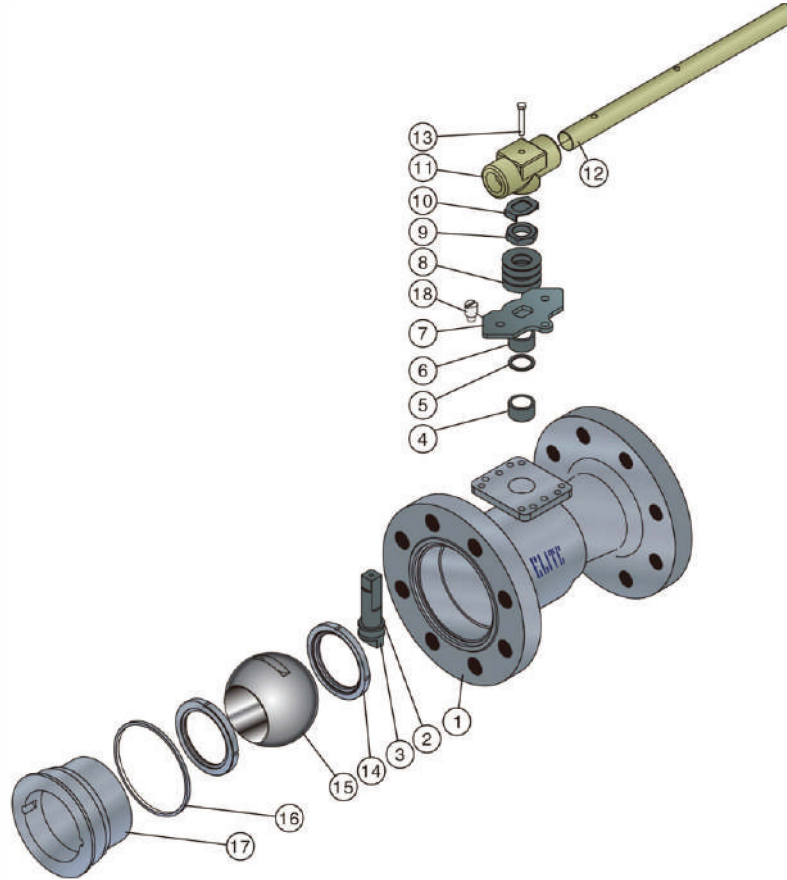

Material

NO.	PART NAME	STANDARD MATERIALS			
		CARBON STEEL	ALLOY STEEL	STAINLESS STEEL	DUPLEX STEEL
1	BODY	A216 WCB	A217 WC6	A351 CF8M	A995 4A
2	THRUST BEARING	PTFE/RPTFE			
3	STEM	A182 F6a/F304/F316		A182 F316/17-4PH/F51	A182 F51/F53/F55
4	STEM PACKING	PTFE/FLEXIBLE GRAPHITE			
5	WASHER	STAINLESS STEEL			
6	GLAND FLANGE	SS410/SS304/SS316		SS316	
7	STOP PLATE	Q235+Zn			
8	BELLEVILLE SPRING	17-7PH/INCONEL 625			
9	GLAND NUT	A194 2H		A194 8/8M	
10	LOCK TAB	STAINLESS STEEL			
11	WRENCH BLOCK	ASTM A216 WCB			
12	HANDLE PIPE	CARBON STEEL+Zn			
13	HANDLE BOLT	A193 B7		A193 B8/B8M	
14	SEAT	PTFE/RPTFE/DEVLON/DERLIN/PEEK			
15	BALL	A105+ENP/A182 F6a/F304/F316		A182 F316/F51	A182 F51/F53/F55
16	BODY GASKET	PTFE/ SS+PTFE/SS+GRAPHITE			
17	END CAP	A105	A182 F11	A182 F316	A182 F51
18	STOP PIN	300 SERIES STAINLESS STEEL			

The material is according to ASTM Standard.

Model Denote:EFC=Elite Flow Control | 1/2=Size in inch | BV=Ball Valve | 1=150Lb | R=RF End | 1=Floating, Split Body.

MODEL NO.:EFC-1/2BV1R1
Size:1/2" ~ 6" (DN15 ~ DN150)
Class:CL150 ~ CL2500



FLOATING TYPE (2PC)

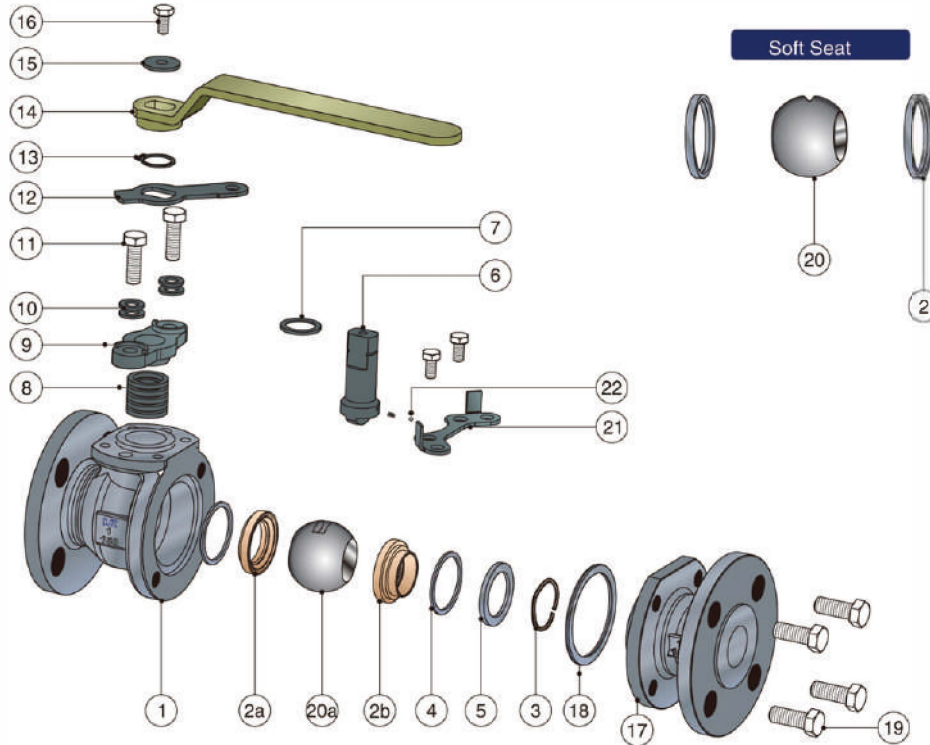

Material

NO.	PART NAME	STANDARD MATERIALS			
		CARBON STEEL	ALLOY STEEL	STAINLESS STEEL	DUPLEX STEEL
1	BODY	A105/A216 WCB	A182 F11/A217 WC6	A182 F316/A351 CF8M	A182 F51/A995 4A
2	SEAT RING	PTFE/RPTFE/DEVLON/DERLIN/PEEK			
2a	SEAT RING	A182 F304+TCC/Ni55		A182 F316+TCC/Ni55	A182 F51+TCC/Ni55
2b	SEAT RING	A182 F304+TCC/Ni55		A182 F316+TCC/Ni55	A182 F51+TCC/Ni55
3	SEAT SPRING	17-7PH/INCONELX-750			
4	SEAT BACKUP SEAL	GRAPHITE			
5	RETAINER	SS304		SS316	A182 F51/F53/F55
6	STEM	A182 F6a/F304/F316		A182 F316/17-4PH/F51	A182 F51/F53/F55
7	THRUST BEARING	PTFE/RPTFE			
8	STEM PACKING	PTFE/FLEXIBLE GRAPHITE			
9	GLAND FLANGE	A216 WCB		A351 CF8/A351 CF8M	
10	BELLEVILLE SPRING	17-7PH/INCONEL 625			
11	GLAND BOLT	A193 B7	A193 B16	A193 B8/A193 B8M	
12	STOPPER	Q235+Zn			
13	SNAP RING	AISI 1065			
14	LEVER	A216 WCB			
15	LEVER WASHER	SS304/SS316			
16	LEVER SET BOLT	A193 B7	A193 B16	A193 B8/A193 B8M	
17	CLOSURE	A105/A216 WCB	A182 F11/A217 WC6	A182 F316/A351 CF8M	A182 F51/A995 4A
18	CLOSURE GASKET	PTFE/ SS+PTFE/SS+GRAPHITE			
19	CLOSURE BOLT	A193 B7	A193 B16	A193 B8/A193 B8M	
20	BALL	A105+ENP/A182 F6a/F304/F316		A182 F316/F51	A182 F51/F53/F55
20a	BALL	A182 F304+TCC/Ni60		A182 F316+TCC/Ni60	A182 F51+TCC/Ni60
21	LOCKING PLATE	Q235+Zn			
22	ANTI STATIC DEVICE	SS316			

The material is according to ASTM Standard.

Model Denote:EFC=Elite Flow Control | 1/2=Size in inch | BV=Ball Valve | 1=150Lb | R=RF End | 1=Floating, Split Body.

FLOATING TYPE (3PC)

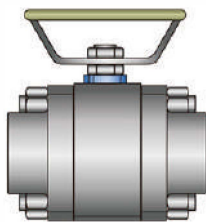
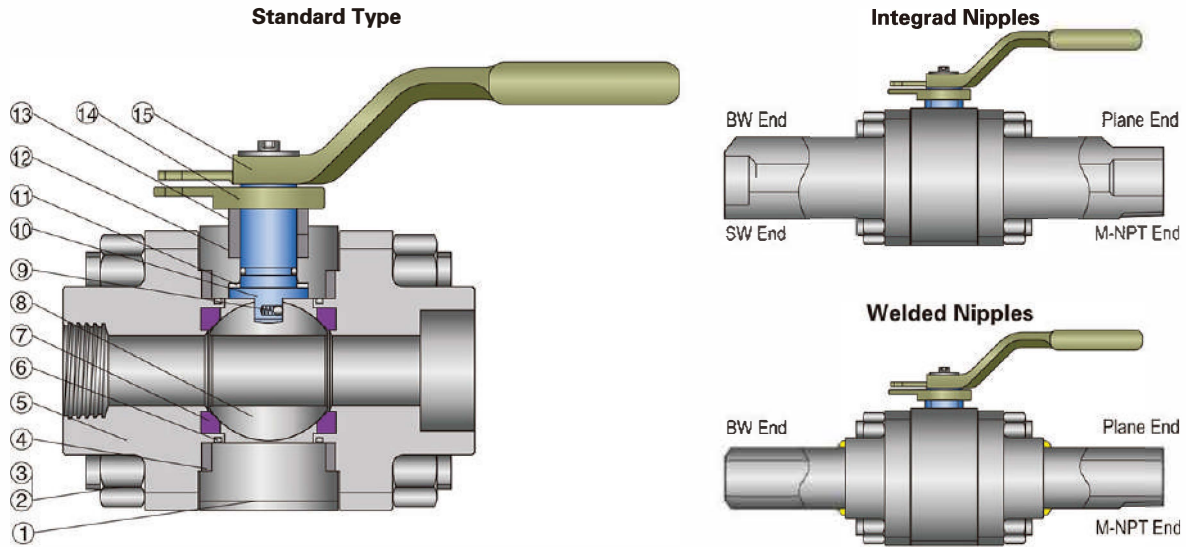

Safety Oval Handle
 Safety Oval Handle are used where the standard lever can be accidentally locked while opening or closing

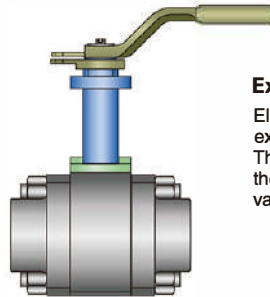

Extended Bonnet For Insulation
 Elite ball valve can be supplied with an extended bonnet . The insulation can be installed all around the valve without blocking access to the valve or other operator

Material

NO.	PART NAME	STANDARD MATERIALS			
		CARBON STEEL	ALLOY STEEL	STAINLESS STEEL	DUPLEX STEEL
1	BODY	A105	A182 F11	A182 F316	A182 F51
2	BOLT	A193 B7	A193 B16	A193 B8/A193 B8M	
3	NUT	A194 2H	A194 4	A194 8/A194 8M	
4	GASKET	SS+GRAPHITE/SS+PTFE			
5	BONNET	A105	A182 F11	A182 F316	A182 F51
6	O-RING	NBR/HNBR/VITON			
7	SEAT RING	PTFE/RPTFE/DEVLON/PPL/PEEK			
8	BALL	A105+ENP/A182 F6a/F304/F316/F51		A182 F316/F51	A182 F51/F53/F55
9	ANTISTATIC SPRING	SS316			
10	STEM	A182 F6a/F304/F316/17-4PH		A182 F316/17-4PH/F51	A182 F51/F53/F55
11	THRUST WASHER	PTFE/RPTFE			
12	PACKING	GRAPHITE/PTFE			
13	GLAND	A276 410/304/316		A276 316	
14	GLAND FLANGE	A216 WCB/A351 CF8		A351 CF8	
15	THE HANDLE	A216 WCB/1025+Zn			

NOTE: Metal-to-metal seated ball valve designs are available upon request.

The material is according to ASTM Standard.

Model Denote: EFC=Elite Flow Control | 1/2=Size in inch | BV=Ball Valve | 8=800Lb | S=SW End | 1=Floating, Split Body.

FLOATING BALL VALVE

Dimension & Weights

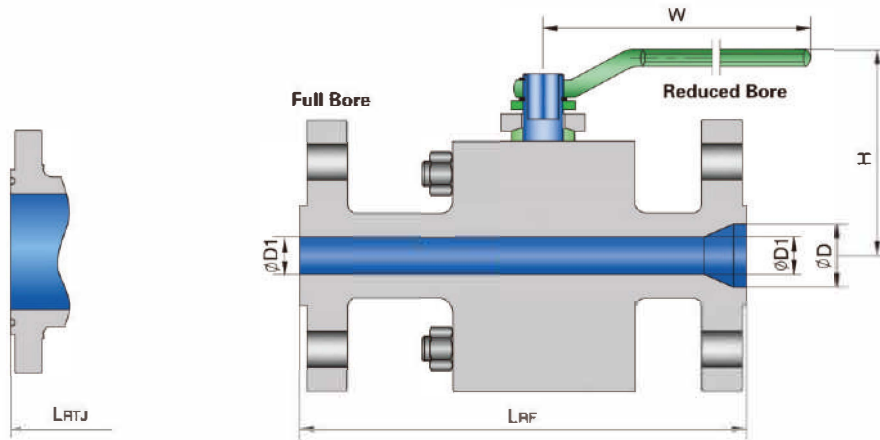

Full Bore

Nominal Pressure	Size		ϕD	$\phi D1$	L		W	H	Weight	
	NPS	DN			RF	RTJ			Lb	Kg
ASME 150	1/2"	15	13	13	108	—	160	76	4.4	2
	3/4"	20	19	19	117	—	200	108	7.0	3.2
	1"	25	25	25	127	140	200	111	10.1	4.6
	1 1/2"	40	38	38	165	178	260	130	15.9	7.2
	2"	50	49	49	178	191	260	160	24.2	11
	3"	80	74	74	203	216	400	184	50.6	23
	4"	100	100	100	229	242	700	203	83.6	38
ASME 300	1/2"	15	13	13	140	151	160	76	5.5	2.5
	3/4"	20	19	19	152	165	200	108	8.8	4.0
	1"	25	25	25	165	178	200	111	13.2	6.0
	1 1/2"	40	38	38	190	203	260	130	25.3	11.5
	2"	50	49	49	216	232	260	160	31.9	14.5
	3"	80	74	74	282	298	400	184	74.8	34
	4"	100	100	100	305	321	700	203	132	60

FLOATING BALL VALVE

Dimension & Weights

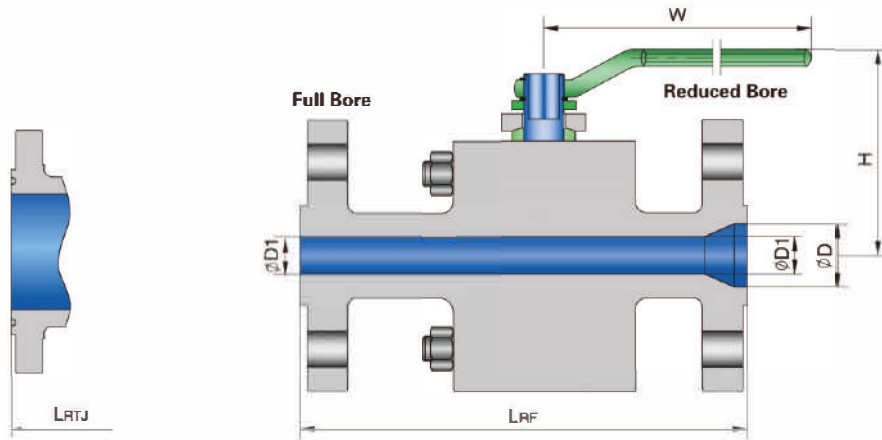

Full Bore

Nominal Pressure	Size		ϕD	$\phi D1$	L		W	H	Weight	
	NPS	DN			RF	RTJ			Lb	Kg
ASME 600	1/2"	15	13	13	165	163	165	80	9.9	4.5
	3/4"	20	19	19	190	190	200	105	13.2	6.0
	1"	25	25	25	216	216	200	110	17.6	8.0
	1 1/2"	40	38	38	241	241	260	130	35.3	16
	2"	50	49	49	292	295	360	140	48.5	22
	3"	80	74	74	356	359	450	185	99.2	45
ASME 900/1500	1/2"	15	13	13	216	216	200	100	15.6	7.1
	3/4"	20	19	19	229	229	200	110	23.1	10.5
	1"	25	25	25	254	254	260	125	38.6	17.5
	1 1/2"	40	38	38	305	305	360	158	63.4	29
	2"	50	49	49	368	371	360	165	83.8	38
ASME 2500	1/2"	15	13	13	264	264	200	100	22	10
	3/4"	20	19	19	273	273	200	110	30.9	14
	1"	25	25	25	308	308	260	125	44	20

FLOATING BALL VALVE

Dimension & Weights

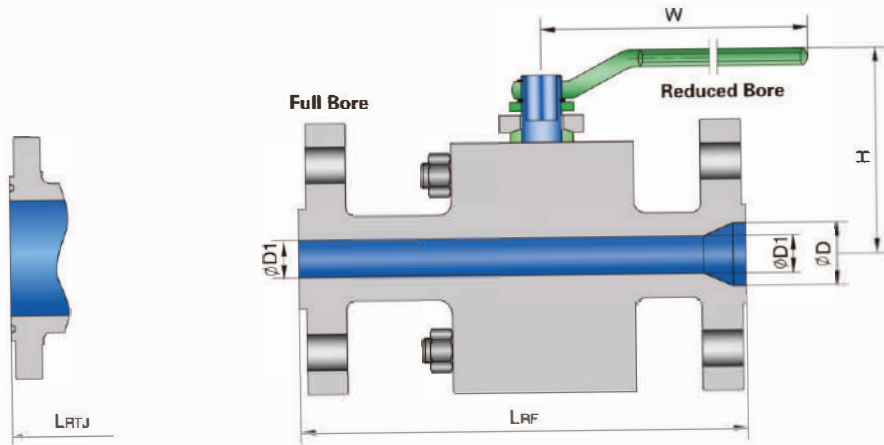

Reduced Bore

Nominal Pressure	Size		ØD	ØD1	L		W	H	Weight	
	NPS	DN			RF	RTJ			Lb	Kg
ASME 150	1/2"	15	13	10	108	—	160	76	4.0	1.8
	3/4"	20	19	13	117	—	160	76	5.5	2.5
	1"	25	25	19	127	140	200	108	7.9	3.6
	1 1/2"	40	38	32	165	178	200	111	12.1	5.5
	2"	50	49	38	178	191	260	130	18.7	8.5
	3"	80	74	49	203	216	260	160	41.8	19
	4"	100	100	74	229	242	400	184	63.8	29
ASME 300	6"	150	150	100	394	407	700	203	154	70
	1/2"	15	13	10	140	151	160	76	4.8	2.2
	3/4"	20	19	13	152	165	160	76	7.3	3.3
	1"	25	25	19	165	178	200	108	11	5.0
	1 1/2"	32	38	32	190	203	200	111	20.3	9.2
	2"	50	49	38	216	232	260	130	28.6	13
	3"	80	74	49	282	298	260	160	59.4	27
	4"	100	100	74	305	321	400	184	99	45
6"	150	150	100	403	419	700	203	176	80	

TRUNNION TYPE (CASTING)

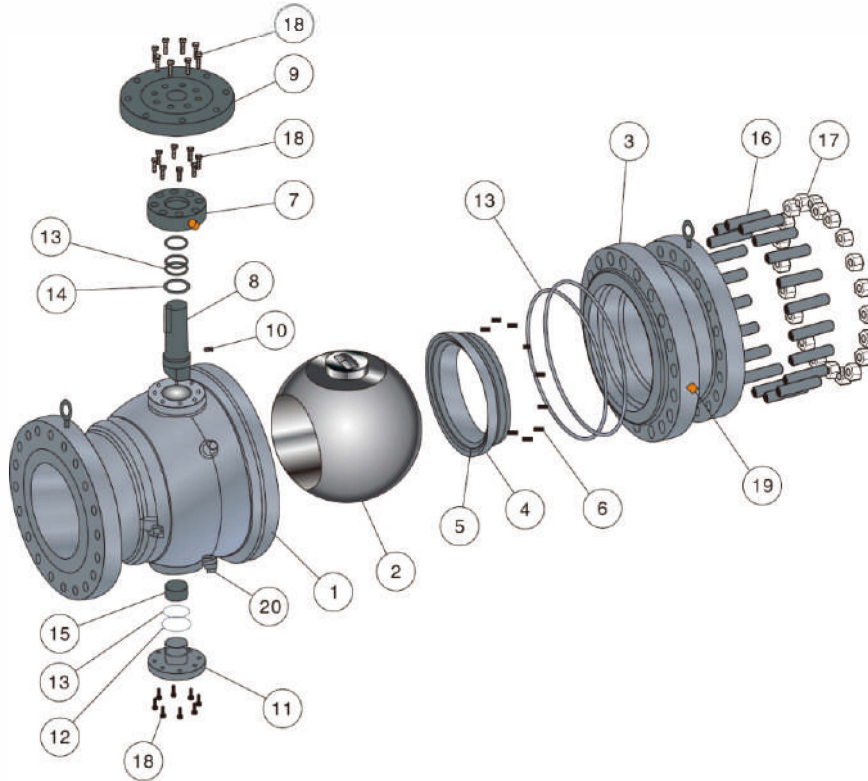

Material

NO.	PART NAME	STANDARD MATERIALS			
		CARBON STEEL	ALLOY STEEL	STAINLESS STEEL	DUPLEX STEEL
1	BODY	A216 WCB	A217 WC6	A351 CF8M	A995 4A
2	BALL	A105+ENP/A182 F6a/F304/F316/F51		A182 F316/F51	A182 F51/F53/F55
3	CLOSURE	A216 WCB	A217 WC6	A351 CF8M	A995 4A
4	SEAT RING	A105+ENP/A182 F6a/F304/F316/F51		A182 F316/F51	A182 F51/F53/F55
5	SEAT INSERT	PTFE/RPTFE/NYLON/DEVLON/PEEK			
6	SPRING	17-7PH/INCONELX-750			
7	STUFFING BOX	A105+ENP	A105+ENP	A182 F316	A182 F51
8	STEM	A182 F6a/F304/F316/17-4PH		A182 F316/17-4PH/F51	A182 F51/F53/F55
9	CONNECTION PLATE	A105	A105	A182 F316	A182 F51
10	ANTI STATIC DEVICE	SS316			
11	LOW TRUNNION	A105+ENP	A105+ENP	A182 F316	A182 F51
12	CLOSURE GASKET	SS+GRAPHITE/SS+PTFE			
13	O-RING	VITON/NBR/HNBR/FVMQ			
14	THRUST WASHER	PTFE/RPTFE			
15	BEARING	SS+PTFE/SS			
16	CLOSURE STUD	A193 B7	A193 B16	A193 B8/A193 B8M	
17	CLOSURE NUT	A194 2H	A194 4	A194 8/A194 8M	
18	CAP SCREW	A193 B7	A193 B16	A193 B8/A193 B8M	
19	SEALANT FITTING	CARBON STEEL		SATINLESS STEEL	
20	DRAIN VALVE	CARBON STEEL		SATINLESS STEEL	

NOTE: Metal-to-metal seated ball valve designs are available upon request.

The material is according to ASTM Standard.

Model Denote: EFC=Elite Flow Control | 02=Size in inch | BV=Ball Valve | 1=150Lb | R=RF End | 3=Trunnion, Split Body.

MODEL NO.:EFC-02BV1R3
 Size:2" ~ 48" (DN50 ~ DN1200)
 Class:CL150 ~ CL2500



TRUNNION TYPE (FORGED)

Trunnion Block(8" ~ 48")

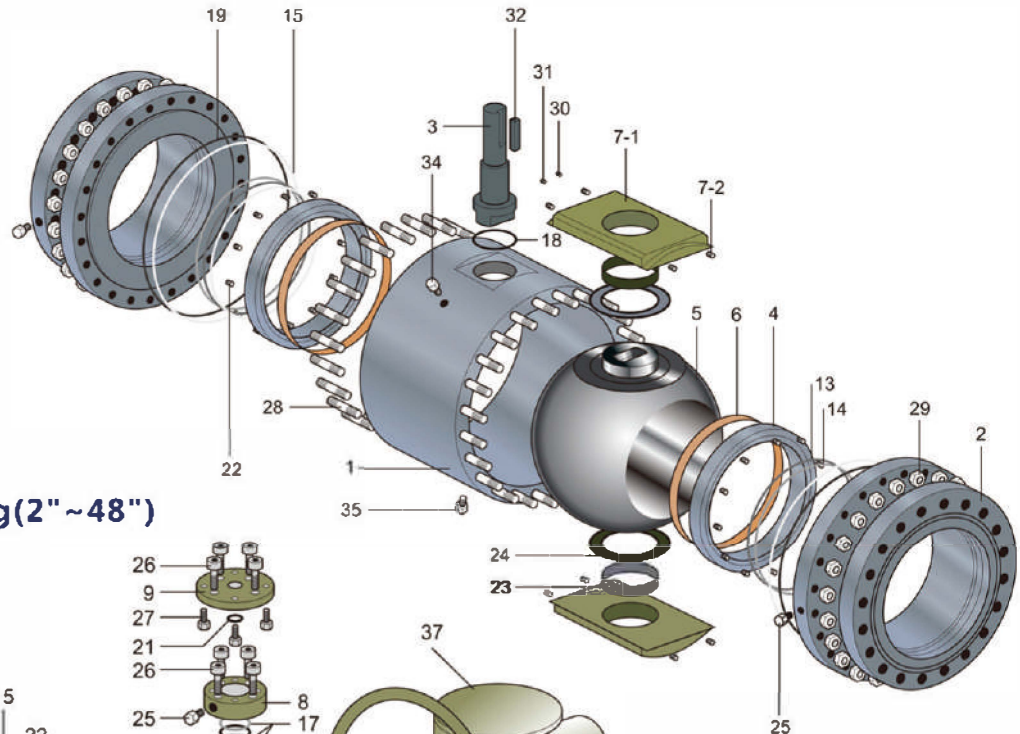

Trunnion Mounting(2" ~ 48")

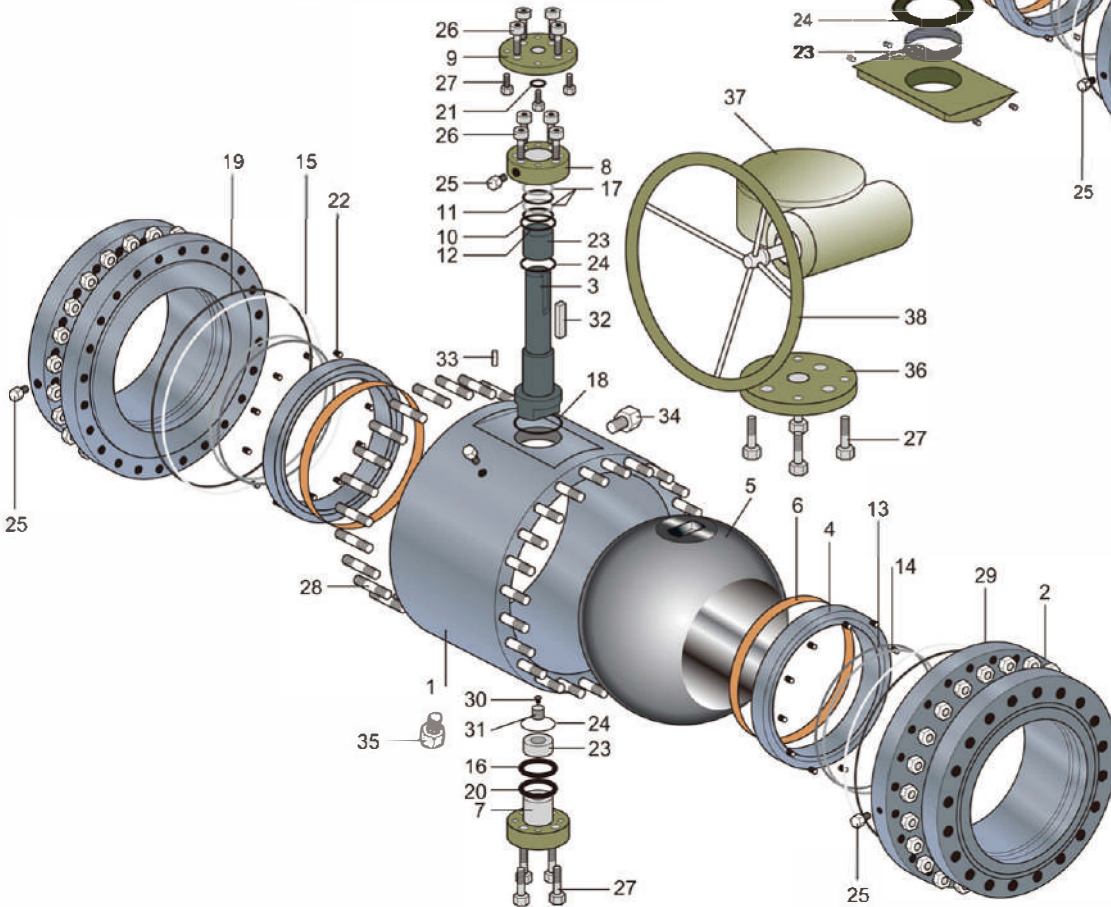

The material is according to ASTM Standard.
 Model Denote:EFC=Elite Flow Control | 02=Size in inch | BV=Ball Valve | 1=150Lb | R=RF End | 3=Trunnion, Split Body.



MODEL NO.:EFC-02BV1R3
Size:2" ~ 48" (DN50 ~ DN1200)
Class:CL150 ~ CL2500

TRUNNION TYPE (FORGED)

NO.	PART NAME	STANDARD MATERIALS			
		CARBON STEEL	ALLOY STEEL	STAINLESS STEEL	DUPLEX STEEL
1	BODY	A105	A182 F11	A182 F316	A182 F51
2	CLOSURE	A105	A182 F11	A182 F316	A182 F51
3	STEM	A182 F6a/F304/F316/17-4PH		A182 F316/F51	A182 F51/F53/F55
4	SEAT RING	A105+ENP/A182 F6a/F304/F316/F51		A182 F316/F51	A182 F51/F53/F55
5	BALL	A105+ENP/A182 F6a/F304/F316/F51		A182 F316/F51	A182 F51/F53/F55
6	SEAT INSERT	PTFE/RPTFE/NYLON/DEVLON/PEEK			
7	TRUNNION MOUNTING	A105+ENP/A182 F11		A182 F316	A182 F51
7-1	TRUNNION BLOCK	A105+ENP/A182 F11		A182 F316	A182 F51
7-2	TRUNNION BLOCK PIN	SS410/SS304/SS316		SS316	SS316
8	STUFFING BOX	A105+ENP		A182 F316	A182 F51
9	CONNECTION PLATE	A105+ENP		A182 F316	A182 F51
10	STEM O-RING	VITON/NBR/HNBR/FVMQ			
11	STEM O-RING	VITON/NBR/HNBR/FVMQ			
12	GLAND O-RING	VITON/NBR/HNBR/FVMQ			
13	SEAT O-RING	VITON/NBR/HNBR/FVMQ			
14	SEAT SUBSEAL	VITON/NBR/HNBR/FVMQ/GRAPHITE			
15	CLOSURE O-RING	VITON/NBR/HNBR/FVMQ			
16	TRUNNION O-RING	VITON/NBR/HNBR/FVMQ			
17	BACKUP RING	PTFE/NYLON			
18	GLAND GASKET	SS+GRAPHITE/SS+PTFE			
19	CLOSURE GASKET	SS+GRAPHITE/SS+PTFE			
20	TRUNNION O-RING	VITON/NBR/HNBR/FVMQ			
21	STEM PACKING	PTFE/GRAPHITE			
22	SEAT SPRING	17-7PH/INCONELX-750			
23	BEARING	SS+PTFE/SS+NITRIDING			
24	THRUST WASHER	PTFE/RPTFE/DEVLON			
25	SEALANT FITTING	CARBON STEEL		STAINLESS STEEL	
26	SCREW	A193 B7	A193 B16	A193 B8(M)	
27	SCREW	A193 B7	A193 B16	A193 B8(M)	
28	STUD	A193 B7	A193 B16	A193 B8(M)	
29	NUT	A194 2H	A194 4	A194 8(M)	
30	GROUNDING BALL	STAINLESS STEEL			
31	GROUNDING SPRING	STAINLESS STEEL			
32	STEM KEY	AISI 1045			
33	POSITIONING PIN	CARBON STEEL		STAINLESS STEEL	
34	VENT PLUG	CARBON STEEL		STAINLESS STEEL	
35	DRAIN PLUG	CARBON STEEL		STAINLESS STEEL	
36	CONNECTION PLATE	A105	A105/A182 F11	A182 F316	A182 F51
37	GEAR	DUCTILE IRON,CARBON STEEL			
38	HANDWHEEL	DUCTILE IRON,CARBON STEEL			

NOTE: Metal-to-metal seated ball valve designs are available upon request.
 The material is according to ASTM Standard.

Model Denote: EFC=Elite Flow Control | 02=Size in inch | BV=Ball Valve | 1=150Lb | R=RF End | 3=Trunnion, Split Body.

TRUNNION BALL VALVE

Dimension & Weights

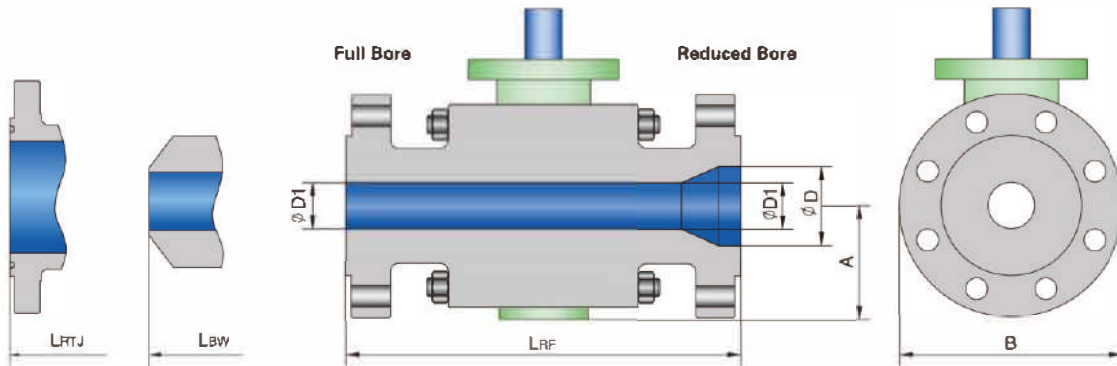

ASME CLASS 150 FULL BORE

Size in/mm	øD	øD1	L			A	B	Weight	
			RF	RTJ	BW			RF/RTJ(Lb/kg)	BW(Lb/kg)
2	1.94	1.94	7	7.5	8.5	3.4	5.9	40	35
50	49	49	178	191	216	86	150	18	16
2 1/2	2.44	2.44	7.5	8	9.5	3.9	7.3	62	55
65	62	62	190	203	241	100	185	28	25
3	2.94	2.94	8	8.5	11.12	4.9	7.8	73	66
80	74	74	203	216	282	125	198	33	30
4	3.94	3.94	9	9.5	12	5.2	9	110	99
100	100	100	229	242	305	132	230	50	45
6	5.94	5.94	15.5	16	18	7.2	12.6	286	271
150	150	150	394	407	457	184	320	130	123
8	7.94	7.94	18	18.5	20.5	9	15.7	506	484
200	201	201	457	470	521	228	398	230	220
10	9.94	9.94	21	21.5	22	10.6	19.1	847	770
250	252	252	533	546	559	268	485	385	350
12	11.94	11.94	24	24.5	25	12.9	22.2	1342	1232
300	303	303	610	623	635	327	565	610	560
14	13.19	13.19	27	27.5	30	14.8	14	1760	1703
350	334	334	686	699	762	375	610	800	774
16	15.19	15.19	30	30.5	33	16	27.9	2640	2420
400	385	385	762	775	838	405	708	1200	1100
18	17.19	17.19	34	34.5	36	18.3	30.1	3388	3124
450	436	436	864	877	914	465	765	1540	1420
20	19.19	19.19	36	36.5	39	21.7	34.3	4048	3850
500	487	487	914	927	991	550	870	1840	1750
22	21.19	21.19	39	39.5	43	22.5	37	4928	4774
550	538	538	991	1004	1092	572	940	2240	2170
24	23.19	23.19	42	42.5	45	24	40.4	6820	6006
600	589	589	1067	1080	1143	610	1026	3100	2730
26	24.94	24.94	45	-	49	24.8	43.7	8030	7524
650	633	633	1143	-	1245	630	1110	3650	3420
28	26.94	26.94	49	-	53	27	46.3	9636	9064
700	684	684	1245	-	1346	685	1175	4380	4120
30	28.94	28.94	51	-	55	28	49.8	11814	10780
750	735	735	1295	-	1397	710	1265	5370	4900
32	30.69	30.69	54	-	60	30.3	53.1	13310	12716
800	779	779	1372	-	1524	770	1350	6050	5780
34	32.69	32.69	58	-	64	31.3	55.1	15180	14146
850	830	830	1473	-	1626	795	1400	6900	6430
36	34.44	34.44	60	-	68	35.6	58.3	18920	16720
900	874	874	1524	-	1727	905	1480	8600	7600
40	38.44	38.44	70.87	-	70.87	37	66.9	24200	21340
1000	976	976	1800	-	1800	940	1700	11000	9700
42	40.19	40.19	74.8	-	74.8	38.4	66.9	31900	24816
1050	1020	1020	1900	-	1900	975	1700	14500	11280
48	45.94	45.94	82.68	-	82.68	42.7	76.4	39600	35420
1200	1166	1166	2100	-	2100	1085	1940	18000	16100

TRUNNION BALL VALVE

Dimension & Weights

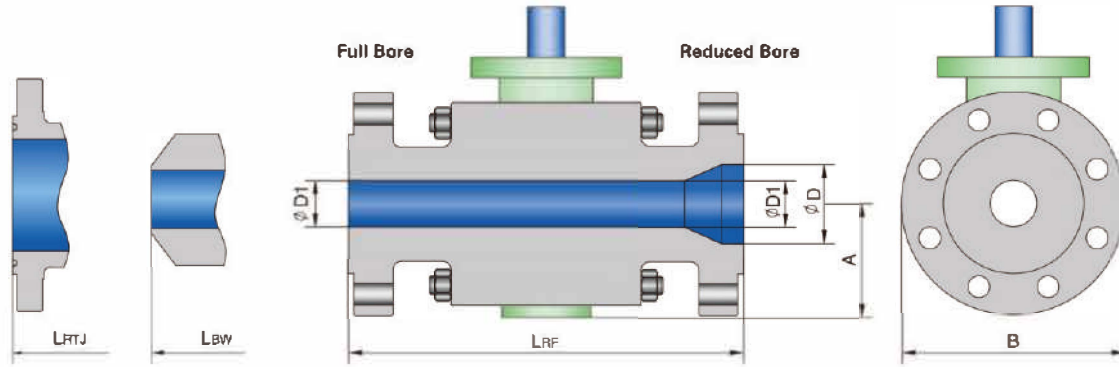

ASME CLASS 150 REDUCED BORE

Size in/mm	ϕD	$\phi D1$	L			A	B	Weight	
			RF	RTJ	BW			RF/RTJ Lb/kg	BW Lb/kg
2 x 1 1/2	1.94	1.5	7	7.5	8.5	3.3	5.9	33	26
50 x 40	49	38	178	191	216	86	150	15	12
2 1/2 x 2	2.44	1.94	7.5	8	9.5	3.3	7.1	49	42
65 x 50	62	49	190	203	241	86	180	22	19
3 x 2	2.94	1.94	8	8.5	11.12	3.3	7.5	55	48
80 x 50	74	49	203	216	282	86	190	25	22
4 x 3	3.94	2.94	9	9.5	12	4.9	9.1	97	81
100 x 80	100	74	229	242	305	125	230	44	37
6 x 4	5.94	3.94	15.5	16	18	5.5	11	154	147
150 x 100	150	100	394	407	457	140	280	70	67
8 x 6	7.94	5.94	18	18.5	20.5	7.2	13.6	436	414
200 x 150	201	150	457	470	521	184	345	198	188
10 x 8	9.94	7.94	21	21.5	22	9	1.6	715	671
250 x 200	252	201	533	546	559	228	405	325	305
12 x 10	11.94	9.94	24	24.5	25	10.6	19.1	913	843
300 x 250	303	252	610	623	635	268	485	415	383
14 x 10	13.19	9.94	27	27.5	30	10.6	21	1151	1104
350 x 250	334	252	686	699	762	268	535	523	502
16 x 12	15.19	11.94	30	30.5	33	12.9	23.4	1639	1551
400 x 300	385	303	762	775	838	327	595	745	705
18 x 14	17.19	13.19	34	34.5	36	14.8	25	2288	2002
450 x 350	436	334	864	877	914	375	635	1040	910
20 x 16	19.19	15.19	36	36.5	39	15.9	27.6	2574	2134
500 x 400	487	385	914	927	991	405	700	1170	970
24 x 20	23.19	19.19	42	42.5	45	21.7	34.3	4213	4026
600 x 500	589	487	1067	1080	1143	550	870	1915	1830
30 x 24	28.94	23.19	51	-	55	24	40.4	8052	7744
750 x 600	735	589	1295	-	1397	610	1026	3660	3520
36 x 30	34.44	28.94	60	-	68	28	49.8	13420	12760
900 x 750	874	735	1524	-	1727	710	1265	6100	5800

TRUNNION BALL VALVE

Dimension & Weights

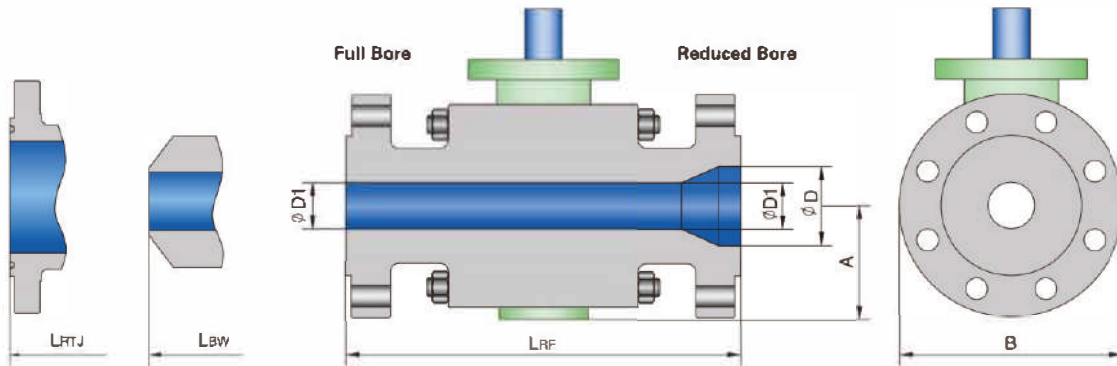

ASME CLASS 300 FULL BORE

Size in/mm	ØD	ØD1	L			A	B	Weight	
			RF	RTJ	BW			RF/RTJ(Lb/kg)	BW(Lb/kg)
2	1.94	1.94	8.5	9.12	8.5	3.6	6.5	62	51
50	49	49	216	232	216	91	165	28	23
2 1/2	2.44	2.44	9.5	10.12	9.5	3.7	7.3	99	92
65	62	62	241	257	241	95	185	45	42
3	2.94	2.94	11.12	11.74	11.12	5	8.3	123	92
80	74	74	282	298	282	126	210	56	42
4	3.94	3.94	12	12.62	12	5.2	10	172	132
100	100	100	305	321	305	132	255	78	60
6	5.94	5.94	15.88	16.5	18	7.4	13	396	308
150	150	150	403	419	457	189	330	180	140
8	7.94	7.94	19.75	20.37	20.5	9	15.7	647	539
200	201	201	502	518	521	228	398	294	245
10	9.94	9.94	22.38	23	22	10.6	19.1	869	726
250	252	252	568	584	559	268	485	395	330
12	11.94	11.94	25.5	26.12	25	12.9	23.2	1463	1232
300	303	303	648	664	635	327	590	665	560
14	13.19	13.19	30	30.62	30	15.2	24.8	2178	1892
350	334	334	762	778	762	385	630	990	860
16	15.19	15.19	33	33.62	33	15.9	28.2	2829	2277
400	385	385	838	854	838	405	716	1286	1035
18	17.19	17.19	36	36.62	36	18.9	31.5	3520	3080
450	436	436	914	930	914	480	800	1600	1400
20	19.19	19.19	39	39.75	39	21.7	34.3	4268	3872
500	487	487	991	1010	991	550	870	1940	1760
22	21.19	21.19	43	43.88	43	22.6	37.8	5390	4840
550	538	538	1092	1114	1092	575	960	2450	2200
24	23.19	23.19	45	45.88	45	24	40.6	6622	6336
600	589	589	1143	1165	1143	610	1030	3010	2880
26	24.94	24.94	49	50	49	24.8	43.1	8404	7810
650	633	633	1245	1270	1245	630	1095	3820	3550
28	26.94	26.94	53	54	53	27.6	46.9	10604	9372
700	684	684	1346	1371	1346	700	1190	4820	4260
30	28.94	28.94	55	56	55	28	49.8	12320	11330
750	735	735	1397	1422	1397	710	1265	5600	5150
32	30.69	30.69	60	61.12	60	30.7	53.1	14190	12430
800	779	779	1524	1552	1524	780	1350	6450	5650
34	32.69	32.69	64	65.12	64	31.9	47.8	15510	14190
850	830	830	1626	1654	1626	810	1215	7050	6450
36	34.44	34.44	68	69.12	68	35.6	58.3	19800	18480
900	874	874	1727	1755	1727	905	1480	9000	8400
40	38.44	38.44	76.77	-	76.77	37	65	24200	22660
1000	976	976	1950	-	1950	940	1650	11000	10300
42	40.19	40.19	82.68	-	82.68	38.2	66.9	31900	29920
1050	1020	1020	2100	-	2100	970	1700	14500	13600
48	45.94	45.94	85.43	-	85.43	44.1	77.4	39600	37620
1200	1166	1166	2170	-	2170	1120	1965	18000	17100

TRUNNION BALL VALVE

Dimension & Weights

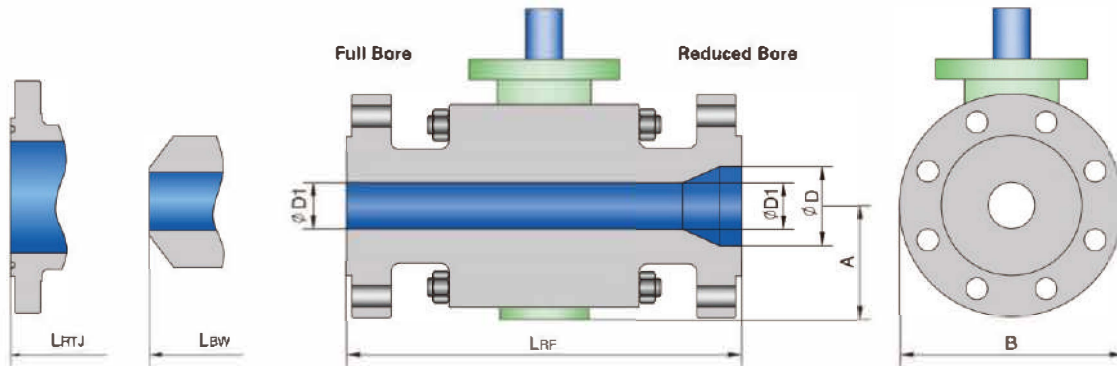

ASME CLASS 300 REDUCED BORE

Size in/mm	ØD	ØD1	L			A	B	Weight	
			RF	RTJ	BW			RF/RTJ Lb/kg	BW Lb/kg
2 × 1 1/2	1.94	1.5	8.5	9.12	8.5	3.5	6.5	40	26
50 × 40	49	38	216	232	216	90	165	18	12
2 1/2 × 2	2.44	1.94	9.5	10.12	9.5	3.6	6.5	57	48
65 × 50	62	49	241	257	241	91	165	26	22
3 × 2	2.94	1.94	11.12	11.74	11.12	3.6	8.3	70	51
80 × 50	74	49	282	298	282	91	210	32	23
4 × 3	3.94	2.94	12	12.62	12	5	10	119	90
100 × 80	100	74	305	321	305	128	255	54	41
6 × 4	5.94	3.94	15.88	16.5	18	6.3	12.6	220	165
150 × 100	150	100	403	419	457	160	320	100	75
8 × 6	7.94	5.94	19.75	20.37	20.5	7.5	15	495	451
200 × 150	201	150	502	518	521	190	380	225	205
10 × 8	9.94	7.94	22.38	23	22	9	17.5	803	748
250 × 200	252	201	568	584	559	228	445	365	340
12 × 10	11.94	9.94	25.5	26.12	25	10.6	20.5	1320	1239
300 × 250	303	252	648	664	635	268	520	600	563
14 × 10	13.19	9.94	30	30.62	30	10.6	23	1430	1327
350 × 250	334	252	762	778	762	268	585	650	603
16 × 12	15.19	11.94	33	33.62	33	12.9	25.6	1782	1586
400 × 300	385	303	838	854	838	327	650	810	721
18 × 14	17.19	13.19	36	36.62	36	15.2	28	3300	3102
450 × 350	436	334	914	930	914	385	710	1500	1410
20 × 16	19.19	15.19	39	39.75	39	16	30.5	4290	3630
500 × 400	487	385	991	1010	991	405	775	1950	1650
24 × 20	23.19	19.19	45	45.88	45	21.7	36	5500	4950
600 × 500	589	487	1143	1165	1143	550	915	2500	2250
30 × 24	28.94	23.19	55	56	55	24	42.9	9350	8492
750 × 600	735	589	1397	1422	1397	610	1090	4250	3860
36 × 30	34.44	28.94	68	69.12	68	28	50	13900	12892
900 × 750	874	735	1727	1755	1727	710	1270	6350	5860

TRUNNION BALL VALVE

Dimension & Weights

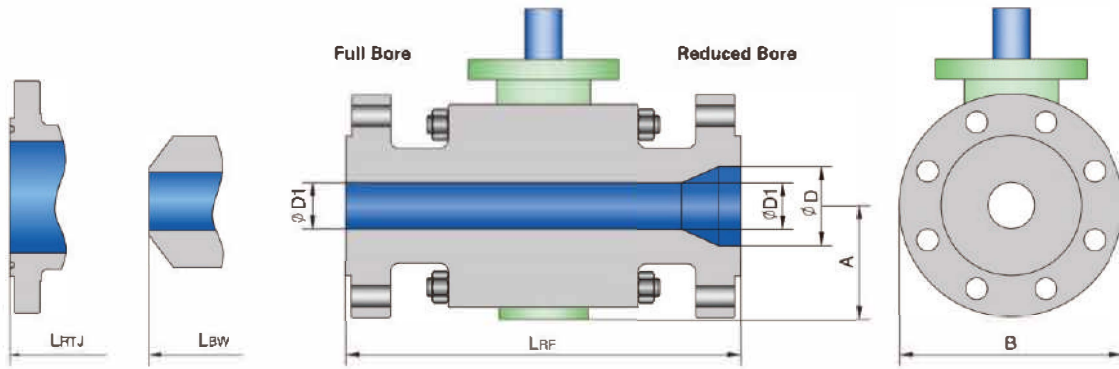

ASME CLASS 600 FULL BORE

Size in/mm	øD	øD1	L			A	B	Weight	
			RF	RTJ	BW			RF/RTJ(Lb/kg)	BW(Lb/kg)
2	1.94	1.94	11.5	11.62	11.5	3.7	6.5	73	62
50	49	49	292	295	292	95	165	33	28
2 1/2	2.44	2.44	13	13.12	13	3.9	7.7	119	106
65	62	62	330	333	330	100	195	54	48
3	2.94	2.94	14	14.12	14	5	8.3	150	110
80	74	74	356	359	356	128	210	68	50
4	3.94	3.94	17	17.12	17	5.8	11.6	242	209
100	100	100	432	435	432	148	295	110	95
6	5.94	5.94	22	22.12	22	7.7	14	528	444
150	150	150	559	562	559	195	355	240	202
8	7.94	7.94	26	26.12	26	9.6	16.5	796	638
200	201	201	660	663	660	245	420	362	290
10	9.94	9.94	31	31.12	31	11.4	20	1166	898
250	252	252	787	790	787	290	510	530	408
12	11.94	11.94	33	33.12	33	14.2	22.8	1727	1430
300	303	303	838	841	838	360	580	785	650
14	13.19	13.19	35	35.12	35	15.6	25	2376	2002
350	334	334	889	891	889	395	635	1080	910
16	15.19	15.19	39	39.12	39	16.7	28.3	3564	3080
400	385	385	991	994	991	425	720	1620	1400
18	17.19	17.19	43	43.12	43	19.3	32.3	3982	3630
450	436	436	1092	1095	1092	490	820	1810	1650
20	19.19	19.19	47	47.25	47	22.6	36.2	5500	4814
500	487	487	1194	1200	1194	575	920	2500	2190
22	21.19	21.19	51	51.38	51	23.2	37.8	6270	5544
550	538	538	1295	1305	1295	590	960	2850	2520
24	23.19	23.19	55	55.38	55	23.8	41	8492	7612
600	589	589	1397	1407	1397	605	1043	3860	3460
26	24.94	24.94	57	57.5	57	25.6	43.9	9504	8470
650	633	633	1448	1461	1448	650	1115	4320	3850
28	26.94	26.94	61	61.5	61	26.8	48	12848	11660
700	684	684	1549	1562	1549	680	1220	5840	5300
30	28.94	28.94	65	65.5	65	29.9	51.8	15686	14080
750	735	735	1651	1664	1651	760	1315	7130	6400
32	30.69	30.69	70	70.62	70	31.1	55.5	20240	18260
800	779	779	1778	1794	1778	790	1410	9200	8300
34	32.69	32.69	76	76.62	76	33.1	56.3	22660	20900
850	830	830	1930	1946	1930	840	1480	10300	9500
36	34.44	34.44	82	82.62	82	35	60.9	25740	23100
900	874	874	2083	2099	2083	890	1546	11700	10500
40	38.44	38.44	80.71		80.71	37.8	65.6	31460	29172
1000	976	976	2050		2050	960	1665	14300	13260
42	40.19	40.19	82.68		82.68	40.9	72.8	36080	33660
1050	1020	1020	2100		2100	1040	1850	16400	15300
48	45.94	45.94	94.49		94.49	46.9	78.3	49940	46200
1200	1166	1166	2400		2400	1190	1990	22700	21000

TRUNNION BALL VALVE

Dimension & Weights

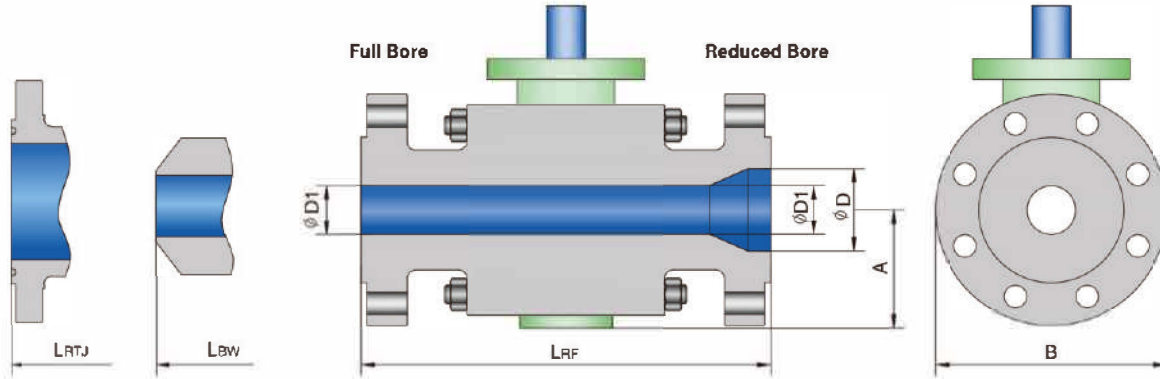

ASME CLASS 600 REDUCED BORE

Size in/mm	ϕD	$\phi D1$	L			A	B	Weight	
			RF	RTJ	BW			RF/RTJ Lb/kg	BW Lb/kg
2 x 1 1/2	1.94	1.5	11.5	11.62	11.5	3.7	6.5	48	35
50 x 40	49	38	292	295	292	94	165	22	16
2 1/2 x 2	2.44	1.94	13	13.12	13	3.7	7.5	64	55
65 x 50	62	49	330	333	330	95	190	29	25
3 x 2	2.94	1.94	14	14.12	14	3.7	8.3	81	55
80 x 50	74	49	356	359	356	95	210	37	25
4 x 3	3.94	2.94	17	17.12	17	5.4	10.8	163	110
100 x 80	100	74	432	435	432	138	275	74	50
6 x 4	5.94	3.94	22	22.12	22	7	14	330	187
150 x 100	150	100	559	562	559	178	355	150	85
8 x 6	7.94	5.94	26	26.12	26	8.3	16.5	638	528
200 x 150	201	150	660	663	660	210	420	290	240
10 x 8	9.94	7.94	31	31.12	31	9.6	20	1067	880
250 x 200	252	201	787	790	787	245	510	485	400
12 x 10	11.94	9.94	33	33.12	33	11.4	22	1463	1100
300 x 250	303	252	838	841	838	290	560	665	500
14 x 10	13.19	9.94	35	35.12	35	11.4	23.8	2266	2002
350 x 250	334	252	889	892	889	290	605	1030	910
16 x 12	15.19	11.94	39	39.12	39	14.1	27	2530	2200
400 x 300	385	303	991	994	991	360	685	1150	1000
18 x 14	17.19	13.19	43	43.12	43	15.6	29.3	3630	2860
450 x 350	436	334	1092	1095	1092	395	745	1650	1300
20 x 16	19.19	15.19	47	47.25	47	16.7	32	5632	4620
500 x 400	487	385	1194	1200	1194	425	815	2560	2100
24 x 20	23.19	19.19	55	55.38	55	22.6	37	6710	5720
600 x 500	589	487	1397	1407	1397	575	940	3050	2600
30 x 24	28.94	23.19	65	65.5	65	23.8	42.9	10780	9240
750 x 600	735	589	1651	1664	1651	605	1090	4900	4200
36 x 30	34.44	28.94	82	82.62	82	35	60.9	20020	17600
900 x 750	874	735	2083	2099	2083	890	1546	9100	8000

TRUNNION BALL VALVE

Dimension & Weights

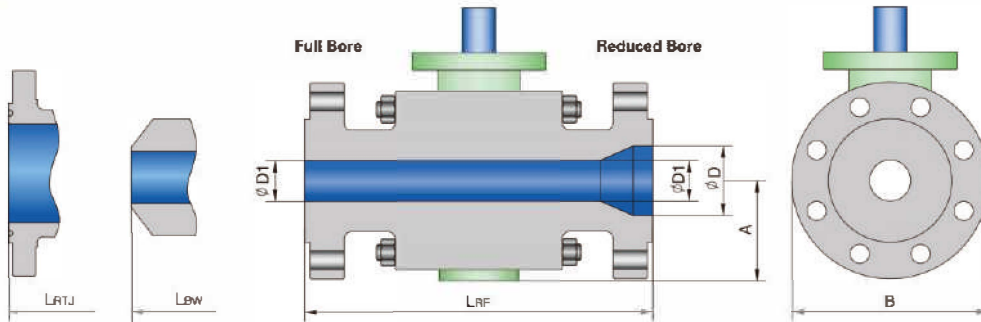

ASME CLASS 900 FULL BORE

Size in/mm	ØD	ØD1	L			A	B	Weight	
			RF	RTJ	BW			RF/RTJ(Lb/kg)	BW(Lb/kg)
2	1.94	1.94	14.5	14.62	14.5	4.3	8.5	128	75
50	49	49	368	371	368	108	215	58	34
2 1/2	2.44	2.44	16.5	16.62	16.5	4.7	9.4	165	123
65	62	62	419	422	419	120	240	75	56
3	2.94	2.94	15	15.12	15	4.8	9.6	183	152
80	74	74	381	384	381	123	245	83	69
4	3.94	3.94	18	18.12	18	5.7	11.4	356	319
100	100	100	457	460	457	145	290	162	145
6	5.94	5.94	24	24.12	24	7.3	15	715	517
150	150	150	610	613	610	185	380	325	235
8	7.94	7.94	29	29.12	29	7.7	18.5	1047	772
200	201	201	737	740	737	295	470	476	351
10	9.94	9.94	33	33.12	33	13.8	21.5	1969	1650
250	252	252	838	841	838	350	545	895	750
12	11.94	11.94	38	38.12	38	14.6	24	2519	2189
300	303	303	965	968	965	370	610	1145	995
14	12.69	12.69	40.5	40.88	40.5	16.9	26.2	3278	2519
350	322	322	1029	1039	1029	430	665	1490	1145
16	14.69	14.69	44.5	44.88	44.5	17.7	29.5	4092	3190
400	373	373	1130	1140	1130	450	750	1860	1450
18	16.69	16.69	48	48.5	48	19.3	32.3	5841	4554
450	423	423	1219	1232	1219	490	820	2655	2070
20	18.56	18.56	52	52.5	52	23.2	36.5	6952	5357
500	471	471	1321	1334	1321	590	928	3160	2435
24	22.44	22.4	61	61.75	61	24.8	41.7	11220	8360
600	570	570	1549	1568	1549	630	1060	5100	3800
26	24.31	24.31	65	65.87	65	26.8	45.7	14850	11968
650	617	617	1651	1672	1651	680	1160	6750	5440
30	28.06	28.06	74	74.87	74	31.5	53.5	25300	21340
750	712	712	1880	1901	1880	800	1360	11500	9700

ASME CLASS 900 REDUCED BORE

Size in/mm	ØD	ØD1	L			A	B	Weight	
			RF	RTJ	BW			RF/RTJ(Lb/kg)	BW(Lb/kg)
2 x 1 1/2	1.94	1.5	14.5	14.62	14.5	4.3	8.5	99	55
50 x 40	49	38	368	371	368	108	215	45	25
2 1/2 x 2	2.44	1.94	16.5	16.62	16.5	4.3	9.6	123	81
65 x 50	62	49	419	422	419	108	245	56	37
3 x 2	2.94	1.94	15	15.12	15	4.3	9.4	143	110
80 x 50	74	49	381	384	381	108	240	65	50
4 x 3	3.94	2.94	18	18.12	18	5.7	11.4	238	172
100 x 80	100	74	457	460	457	145	290	108	78
6 x 4	5.94	3.94	24	24.12	24	7.5	15	462	330
150 x 100	150	100	610	613	610	190	380	210	150
8 x 6	7.94	5.94	29	29.12	29	9.3	18.5	715	528
200 x 150	201	150	737	740	737	235	470	325	240
10 x 8	9.94	7.94	33	33.12	33	11.3	21.5	902	638
250 x 200	252	201	838	841	838	295	545	410	290
12 x 10	11.94	9.94	38	38.12	38	13	24	2420	1936
300 x 250	303	252	965	968	965	330	610	1100	880
14 x 10	12.69	9.94	40.5	40.88	40.5	13	25.2	3190	2816
350 x 250	322	252	1029	1039	1029	330	640	1450	1280
16 x 12	14.69	11.94	44.5	44.88	44.5	14.6	27.7	3608	2970
400 x 300	373	303	1130	1140	1130	370	705	1640	1350
18 x 14	16.69	12.69	48	48.5	48	16.9	30.9	5280	4290
450 x 350	423	322	1219	1232	1219	430	795	2400	1950
20 x 16	18.56	14.69	52	52.5	52	17.7	33.7	6292	4730
500 x 400	471	373	1321	1334	1321	450	855	2860	2150
24 x 20	22.44	18.56	61	61.75	61	23.2	40.9	9240	6336
600 x 500	570	471	1549	1568	1549	590	1040	4200	2880
30 x 24	28.06	22.44	74	74.87	74	24.8	48.4	15620	12760
750 x 600	712	570	1880	1901	1880	630	1230	7100	5800

TRUNNION BALL VALVE

Dimension & Weights

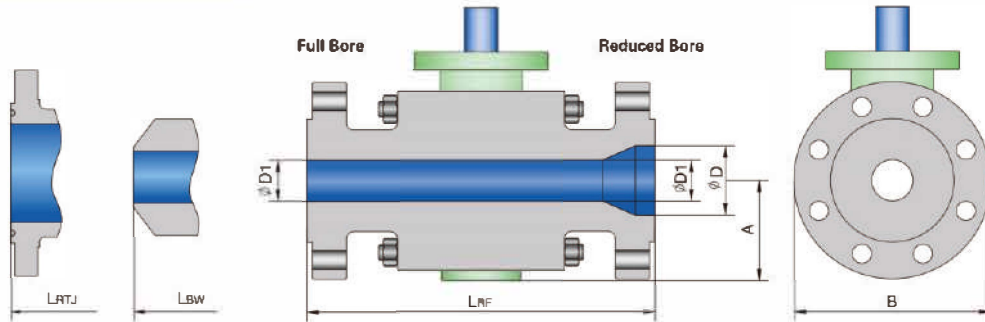

ASME CLASS 1500 FULL BORE

Size in/mm	ØD	ØD1	L			A	B	Weight	
			RF	RTJ	BW			RF/RTJ(lb/kg)	BW(lb/kg)
2	1.94	1.94	14.5	14.62	14.5	4.3	8.5	128	75
50	49	49	368	371	368	108	215	58	34
2 1/2	2.44	2.44	16.5	16.62	16.5	4.8	9.6	174	136
65	62	62	419	422	419	123	245	79	62
3	2.94	2.94	18.5	18.62	18.5	5.5	10.4	216	154
80	74	74	470	473	470	140	265	98	70
4	3.94	3.94	21.5	21.62	21.5	6.5	12.2	365	317
100	100	100	546	549	546	165	310	166	144
6	5.69	5.69	27.75	28	27.75	9.6	16.3	1030	834
150	144	144	705	711	705	219	415	468	379
8	7.56	7.56	32.75	33.13	32.75	11.6	19.1	1478	964
200	192	192	832	842	832	295	485	672	438
10	9.44	9.44	39	39.38	39	14.2	23.6	2222	1716
250	239	239	991	1001	991	360	600	1010	780
12	11.31	11.31	44.5	45.12	44.5	15.7	27.2	3388	2420
300	287	287	1130	1146	1130	400	692	1540	1100
14	12.44	12.44	49.5	50.25	49.5	19.3	30.7	6820	5280
350	315	315	1257	1276	1257	490	780	3100	2400
16	14.19	14.19	54.5	55.38	54.5	24.8	35.5	9900	6072
400	360	360	1384	1406	1384	629	900	4500	2760
18	16	16	60.5	61.38	60.5	25.2	39.4	13420	10670
450	406	406	1537	1559	1537	640	1000	6100	4850
20	17.88	17.88	65.5	66.38	65.5	25.6	41.9	16720	12540
500	454	454	1664	1686	1664	650	1065	7600	5700
24	21.5	21.5	76.5	77.62	76.5	29.9	50.2	21120	15840
600	546	546	1943	1971	1943	760	1275	9600	7200

ASME CLASS 1500 REDUCED BORE

Size in/mm	ØD	ØD1	L			A	B	Weight	
			RF	RTJ	BW			RF/RTJ(lb/kg)	BW(lb/kg)
2 x 1 1/2	1.94	1.5	14.5	14.62	14.5	4.3	8.5	95	48
50 x 40	49	38	368	371	368	108	215	43	22
2 1/2 x 2	2.44	1.94	16.5	16.62	16.5	4.3	9.6	141	92
65 x 50	62	49	419	422	419	108	245	64	42
3 x 2	2.94	1.94	18.5	18.62	18.5	4.3	10.6	165	106
80 x 50	74	49	470	473	470	108	265	75	48
4 x 3	3.94	2.94	21.5	21.62	21.5	6.1	12.2	286	167
100 x 80	100	74	546	549	546	155	310	130	76
6 x 4	5.69	3.94	27.75	28	27.75	7.8	15.6	605	374
150 x 100	144	100	705	711	705	198	395	275	170
8 x 6	7.56	5.69	32.75	33.13	32.75	9.6	19.1	1320	924
200 x 150	192	144	832	842	832	243	485	600	420
10 x 8	9.44	7.56	39	39.38	39	11.6	23	1848	1078
250 x 200	239	192	991	1001	991	295	585	840	490
12 x 10	11.31	9.44	44.5	45.12	44.5	14.2	26.6	2750	1760
300 x 250	287	239	1130	1146	1130	360	675	1250	800
14 x 10	12.44	9.44	49.5	50.25	49.5	14.2	29.5	3630	2970
350 x 250	315	239	1257	1276	1257	360	750	1650	1350
16 x 12	14.19	11.31	54.5	55.38	54.5	15.7	32.5	4517	3520
400 x 300	360	287	1384	1406	1384	400	825	2053	1600
18 x 14	16	12.44	60.5	61.38	60.5	18.7	36	10956	8690
450 x 350	406	315	1537	1559	1537	475	915	4980	3950
20 x 16	17.88	14.19	65.5	66.38	65.5	24.8	38.8	12188	9350
500 x 400	454	360	1664	1686	1664	629	985	5540	4250
24 x 20	21.5	17.88	76.5	77.62	76.5	25.6	46.1	24200	18920
600 x 500	546	454	1943	1971	1943	650	1170	11000	8600

TRUNNION BALL VALVE

Dimension & Weights

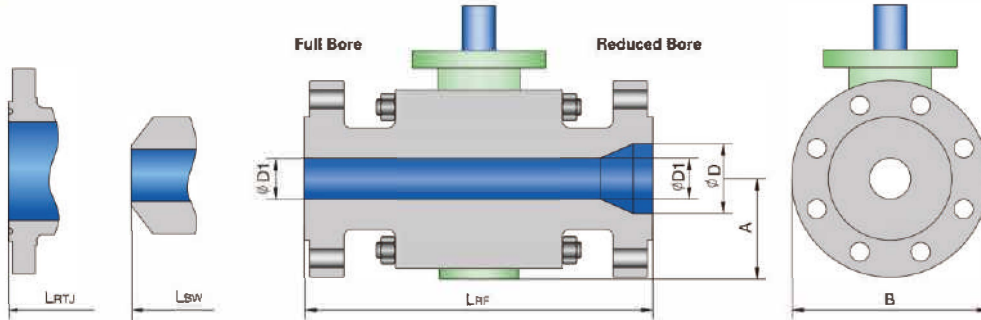

ASME CLASS 2500 FULL BORE

Size in/mm	ØD	ØD1	L			A	B	Weight	
			RF	RTJ	BW			RF/RTJ(Lb/kg)	BW(Lb/kg)
2	1.69	1.69	17.75	17.87	17.75	5.5	9.3	260	154
50	42	42	451	454	451	139	235	118	70
2 1/2	2.06	2.06	20	20.25	20	5.2	10.4	378	275
65	52	52	508	514	508	133	265	172	125
3	2.44	2.44	22.75	23	22.75	6.3	12	484	363
80	62	62	578	584	578	160	305	220	165
4	3.44	3.44	26.5	26.88	26.5	7.4	14	803	715
100	87	87	673	683	673	188	355	365	325
6	5.19	5.19	36	36.5	36	10.8	19.1	1650	1375
150	131	131	914	927	914	275	485	750	625
8	7.06	7.06	40.25	40.87	40.25	15	24.2	4620	3608
200	179	179	1022	1038	1022	380	615	2100	1640
10	8.81	8.81	50	50.88	50	18.9	31.9	6600	5588
250	223	223	1270	1292	1270	480	810	3000	2540
12	10.44	10.44	56	56.88	56	19.7	33.9	9240	7700
300	265	265	1422	1444	1422	500	860	4200	3500

ASME CLASS 2500 REDUCED BORE

Size in/mm	ØD	ØD1	L			A	B	Weight	
			RF	RTJ	BW			RF/RTJ(Lb/kg)	BW(Lb/kg)
2 x 1 1/2	1.69	1.5	17.75	17.87	17.75	4.6	9.3	189	97
50 x 40	42	38	451	454	451	118	235	86	44
2 1/2 x 2	2.06	1.69	20	20.25	20	5.5	10.4	297	242
65 x 50	52	42	508	514	508	139	265	135	110
3 x 2	2.44	1.69	22.75	23	22.75	5.5	12	341	220
80 x 50	62	42	578	584	578	139	305	155	100
4 x 3	3.44	2.44	26.5	26.88	26.5	7	14	627	374
100 x 80	87	62	673	683	673	178	355	285	170
6 x 4	5.19	3.44	36	36.5	36	9.6	19.1	1254	737
150 x 100	131	87	914	927	914	243	485	570	355
8 x 6	7.06	5.19	40.25	40.87	40.25	10.8	21.7	2332	1914
200 x 150	179	131	1022	1038	1022	275	550	1060	870
10 x 8	8.81	7.06	50	50.88	50	15	26.6	5720	4862
250 x 200	223	179	1270	1292	1270	380	675	2600	2210
12 x 10	10.44	8.81	56	56.88	56	18.9	31.9	8074	6864
300 x 250	265	223	1422	1444	1422	480	810	3670	3120

TOP ENTRY BALL VALVE

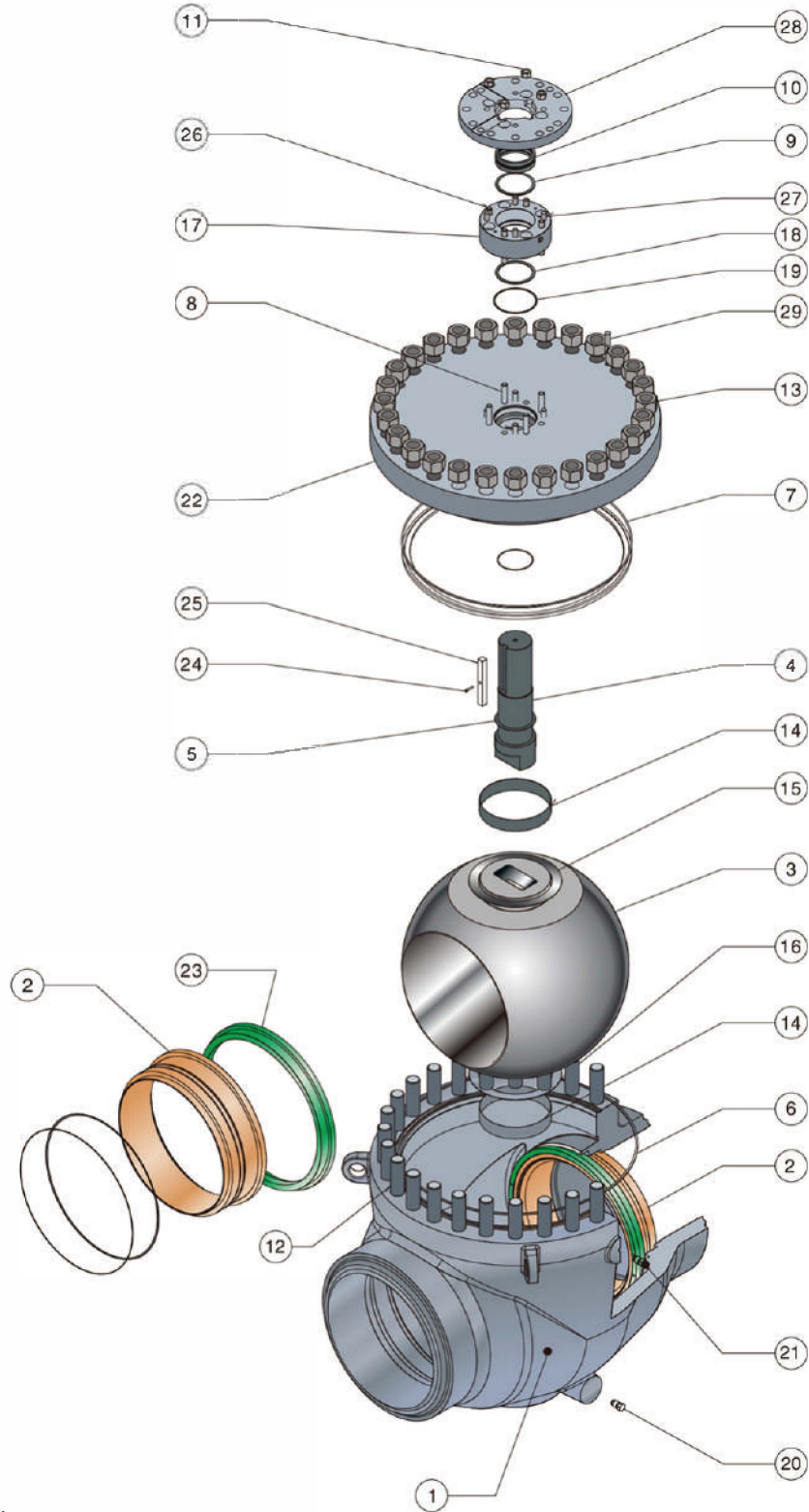

The material is according to ASTM Standard.
 Model Denote:EFC=Elite Flow Control | 02=Size in inch | BV=Ball Valve | 1=150Lb | B=BW End | 5=Top Entry

MODEL NO.:EFC-02BV1B5
Size:2" ~ 36" (DN50 ~ DN900)
Class:CL150 ~ CL2500



TOP ENTRY BALL VALVE

NO.	PART NAME	STANDARD MATERIALS			
		CARBON STEEL	ALLOY STEEL	STAINLESS STEEL	DUPLEX STEEL
1	BODY	A216 WCB	A217 WC6	A351 CF8M	A995 4A
2	SEAT RING	A105+ENP/A182 F6a/F304/F316/F51		A182 F316/F51	A182 F51/F53/F55
3	BALL	A105+ENP/A182 F6a/F304/F316/F51		A182 F316/F51	A182 F51/F53/F55
4	STEM	A182 F6a/F304/F316/17-4PH		A182 F316/F51	A182 F51/F53/F55
5	THRUST WASHER	PTFE/RPTFE/DEVLON			
6	BODY GASKET	SS+GRAPHITE/SS+PTFE			
7	BONNET O-RING	VITON/NBR/HNBR/FVMQ			
8	GLAND STUD	A193 B7	A193 B16	A193 B8(M)	
9	STEM O-RING	VITON/NBR/HNBR/FVMQ			
10	STEM PACKING	PTFE/GRAPHITE			
11	GLAND NUT	A194 2H	A194 4	A194 8(M)	
12	BONNET STUD	A193 B7	A193 B16	A193 B8(M)	
13	BONNET NUT	A194 2H	A194 4	A194 8(M)	
14	BEARING	SS+PTFE/SS+Nitriding			
15	THRUST WASHER	SS+PTFE			
16	THRUST WASHER	SS+PTFE			
17	STUFFING BOX	A105+ENP		A182 F316	A182 F51
18	GLAND GASKET	SS+GRAPHITE/SS+PTFE			
19	GLAND O-RING	VITON/NBR/HNBR/FVMQ			
20	DRAIN PLUG	CARBON STEEL		SATINLESS STEEL	
21	SEALANT FITTING	CARBON STEEL		SATINLESS STEEL	
22	BONNET	A216 WCB	A217 WC6	A351 CF8M	A995 4A
23	SPRING HOLDER RING	A105+ENP/A182 F6a/F304/F316/F51		A182 F316/F51	A182 F51/F53/F55
24	STEM KEY SCREW	A193 B7	A193 B16	A193 B8(M)	
25	STEM KEY	AISI 1045			
26	STUFFING BOX STUD	A193 B7	A193 B16	A193 B8(M)	
27	STUFFING BOX PIN	AISI 1065/SS410/SS304/SS316			
28	CONNECTION PLATE	A105+ENP	A182 F316	A182 F51	
29	BONNET PIN	SS410/SS304/SS316			

DESIGN FEATURES

- Sealant injection to stem and/or seat area.
- Metal seated or primary metal seat with secondary soft insert.
- Extended Bonnet for low or high temperature service.
- Extended Stem for underground installation.
- Locking & interlocking facilities.
- Drain and Vent connections with thread protection or valve(ball/gate..) vent & drain valve fitted.
- Pneumatic, Electric or Hydraulic Automation.
- Emergency Shut Down applications.

The material is according to ASTM Standard.

Model Denote:EFC=Elite Flow Control | 02=Size in inch | BV=Ball Valve | 1=150Lb | B=BW End | 5=Top Entry

FULLY WELDED TRUNNION & EXTENDED STEM BALL VALVE

DESIGN FEATURES

Transition Pups

- Transition pups are supplied on request for welded end valves

Extended Stem

- Valves installed underground or in remote loactions can be operated with an optional extended stem.
- All the drain, vent and emergency sealant connections can be operated using extended connecting pipes firmly attached to the stem protective cover.

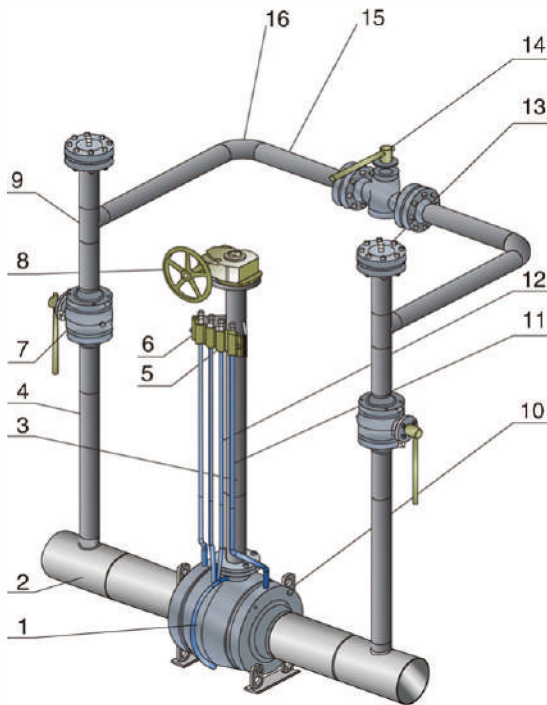

COMPLETE BY-PASS SYSTEM

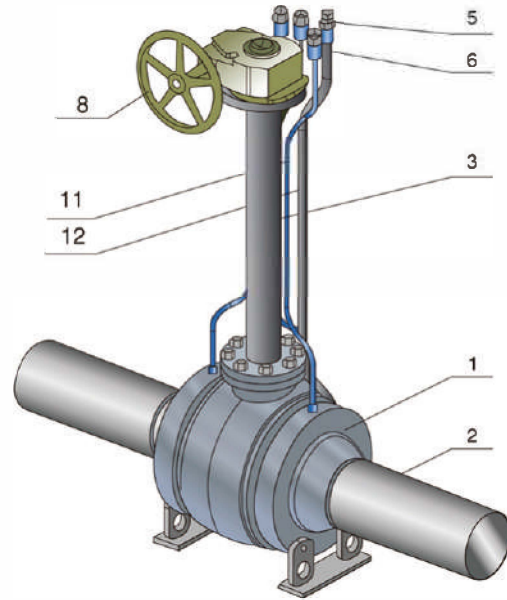

EXTENDED STEM BALL VALVE

Design Feture:

- Full Welded Body and End
- Full Bore
- Trunnion Mounted Ball
- Low Torque
- Under Ground
- Stem and Seat Sealant Injection
- Fire Safely Design
- Anti-blow Out Stem

NO.	PART NAME	SAMPLE MATERIALS	NO.	PART NAME	SAMPLE MATERIALS
1	VALVE	ASTM A105	9	TEE	CARBON STEEL
2	PUPS	API 5L GR.B	10	LIFT LUG	CARBON STEEL
3	EXTEND PIPE	CARBON STEEL	11	LUBRICANT PIPE	ASTM A106
4	BLOW PIPE	ASTM A106	12	DRAIN PIPE	ASTM A106
5	DRAIN VALVE	CARBON STEEL	13	BLIND FLANGE	ASTM A105
6	LUBRICANT FITTING	CARBON STEEL	14	BY-PASS VALVE	ASTM A105
7	CONNECTION VALVE	ASTM A105	15	BY-PASS PIPE	ASTM A106
8	GEAR	ASSEMBLY	16	ELBOW	CARBON STEEL

The material is according to ASTM Standard.

Model Denote:EFC=Elite Flow Control | 02=Size in inch | BV=Ball Valve | 1=150Lb | B=BW End | 4=Trunnion, Welded Body.

MODEL NO.:EFC-02BV1R8
SIZE:1/2" ~ 24" (DN15 ~ DN600)
Class:CL150 ~ CL2500



THREE-WAY BALL VALVE

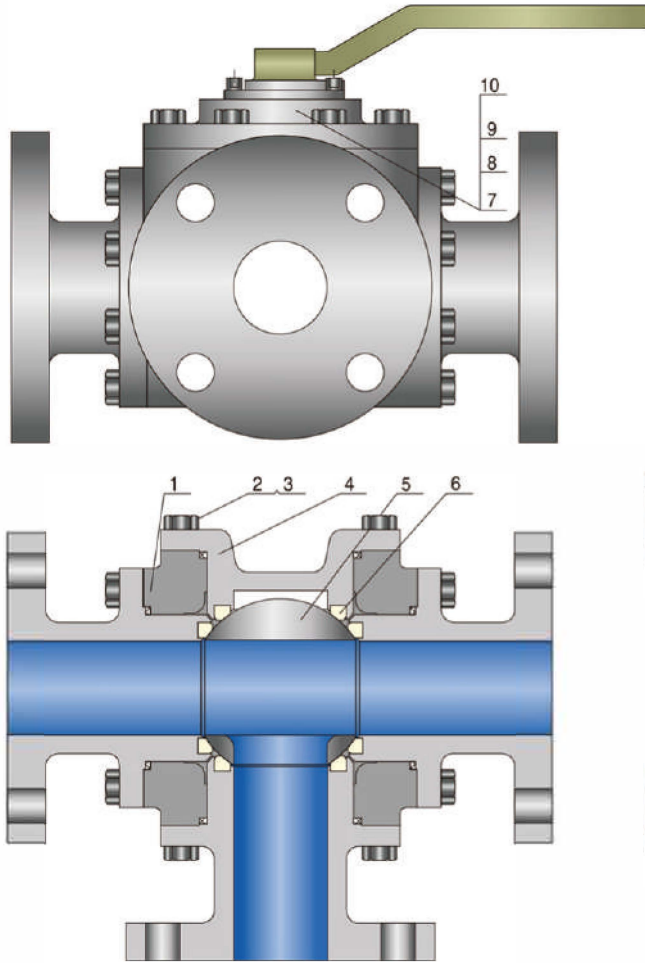

FLOW COMBINATIONS CHART

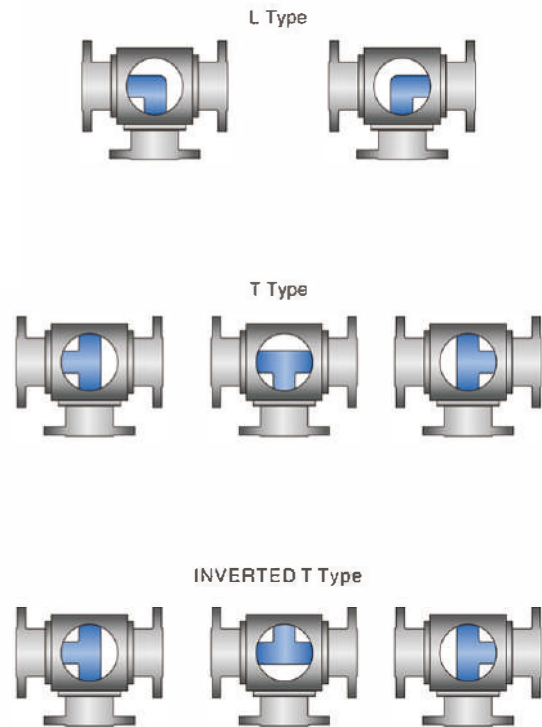

NO.	PART NAME	SAMPLE MATERIALS		
		CARBON STEEL	ALLOY STEEL	STAINLESS STEEL
1	BODY	ASTM A216 WCB/A105	ASTM A217 WC6/A182 F11	ASTM A351 CF8/A182 F304
2	BONNET BOLT	ASTM A193 B7	ASTM A193 B16	ASTM A193 B8
3	BONNET NUT	ASTM A194 2H	ASTM A194 4	ASTM A194 8
4	BONNET	ASTM A216 WCB/A105	ASTM A217 WC6/A182 F11	ASTM A351 CF8/A182 F304
5	BALL	A105+ENP/A182 F6a/F304/F316/F51		ASTM A182 F304/F316/F51
6	SEAT	PTFE/RPTFE/NYLON/DEVLON/PEEK		
7	STEM	ASTM A182 F6a/F304/F316/F51		ASTM A182 F304/F316
8	THRUST WASHER		PTFE/RPTFE	
9	STEM PACKING	GRAPHITE	GRAPHITE	GRAPHITE
10	LEVER	CARBON STEEL	CARBON STEEL	CARBON STEEL

NOTE: Metal-to-metal seated ball valve designs are available upon request.
 The material is according to ASTM Standard
 Model Denote: EFC=Elite Flow Control | 02=Size in inch | BV=Ball Valve | 1=150Lb | R=RF End | 8=Three-Way

DOUBLE BLOCK AND BLEED BALL VALVE

FLOATING TYPE

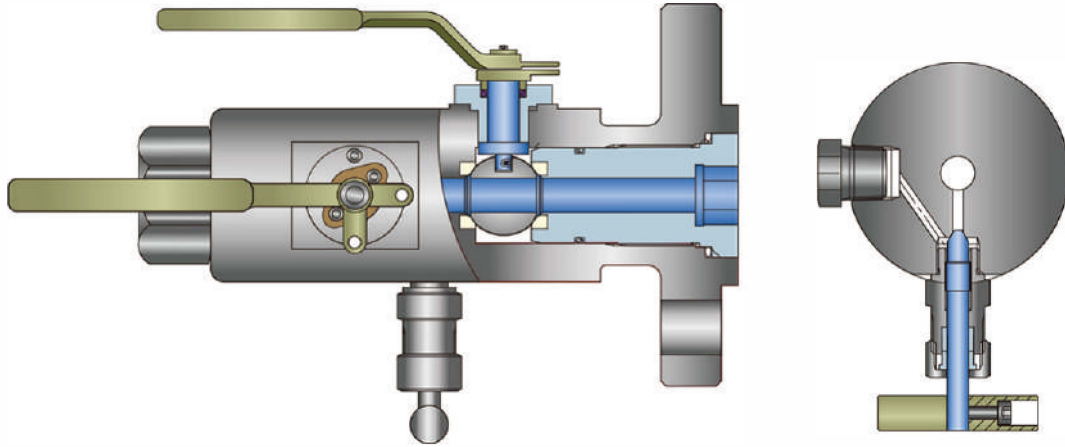

Bleeder Type:

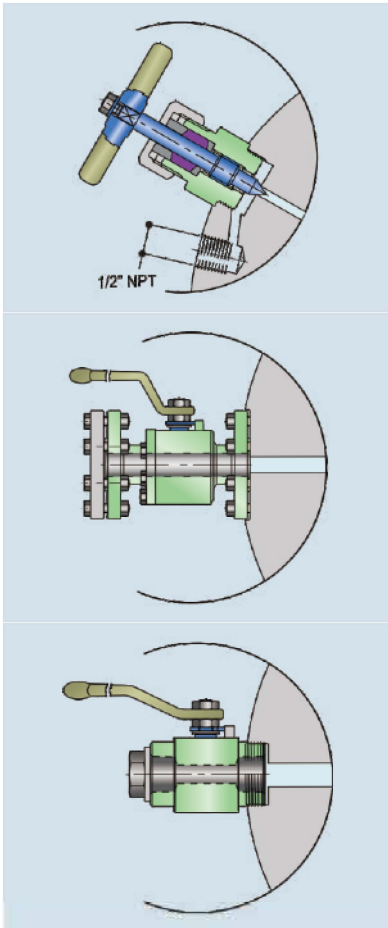

A

Standard Version:
Needle valve screwed into the valve body with
1/2" NPTF bleed.

B

Floating Ball Valve, Bolted to the valve
body; that valve is provided with blind flange.

C

Floating Ball Valve, Screwed to the
valve body; that valve is provided with plug.



The material is according to ASTM Standard.

Model Denote:EFC=Elite Flow Control | 1/2=Size in inch | BV=Ball Valve | 1=150Lb | R=RF End | 6=Floating, DBB Type.

MODEL NO.:EFC-02BV1R7
 Size:2" ~ 24"(DN50 ~ DN600)
 Class:CL150 ~ CL2500



DOUBLE BLOCK AND BLEED BALL VALVE

TRUNNION TYPE

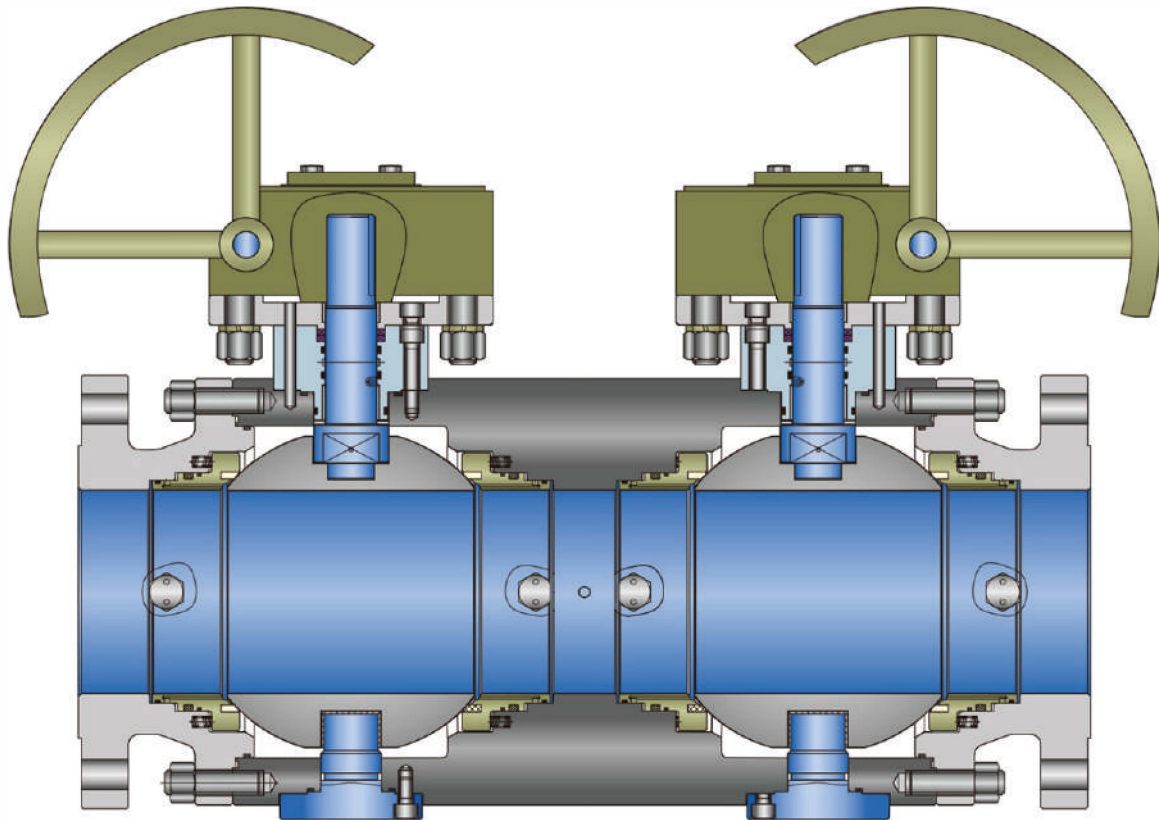

PRODUCT RANGE				
SERVICE	CL150~600	CL900	CL1500	CL2500
FLOATING TYPE	1/2"~6"	1/2"~2"	1/2"~2"	1/2"~1"
TRUNNION TYPE	2"~24"	2"~24"	2"~24"	2"~12"

DESIGN FEATURES

- Forged Body
- Flange Connection according. to ASME B16.5
- Face to Face according. to supplier recommendation
- Lever lockable and removable,Gear box operation as Standard.Actuator mounting flanges,unless otherwise specified,are in full according with ISO 5211
- Soft Seat or Metal Seat
- Double Piston Effect
- Vent Connections:
 Integral Vent Valve-- Needle Type
 Screwed Bonnet or Flanged Bonnet
 Screwed Vent Valve--Ball Valve

The material is according to ASTM Standard.
 Model Denote:EFC=Elite Flow Control | 02=Size in inch | BV=Ball Valve | 1=150Lb | R=RF End | 7=Trunnion, DBB Type.

SEAT & SEAL DESIGN FEATURES

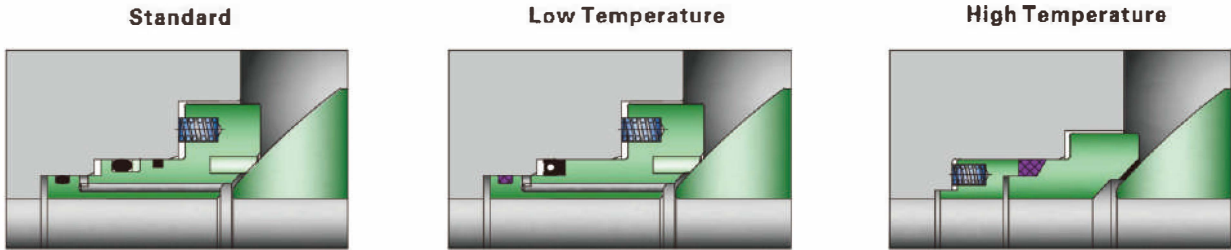

Optional Seat Selections

Material	Operating Temperature	Operating Pressure	Description
PTFE	-80~120°C -112~248°F	150LB	PTFE is a fluorocarbon-based polymer. This material has the lowest operational torques due to its lower coefficient of friction.
RPTFE	-80~120°C -112~248°F	150~600LB	RPTFE (Reinforced PTFE). Properties are enhanced by adding a percentage of filler material to provide improved strength, stability, and wear resistance.
PCTFE	-190~120°C -310~248°F	150~300LB	PCTFE is a thermoplastic chlorofluoropolymer, dimensionally stable, rigid, and resistant to cold flow, Very low gas permeation and outgassing, Low deformation under load
PPL	-45~250°C -49~482°F	150~300LB	PPL (Polyparaphenylene) is an excellent seat material with low coefficient of friction, highly resistant to pressure and temperature.
NYLON	-29~80°C -20~176°F	150~1500LB	Nylon is offered for high pressure applications. The material is ideal for use in high pressure air, oil, and other gas media but is not suitable for strong oxidizing agents
MOLON	-29~130°C -20~266°F	150~1500LB	Molon is a modified Nylon (Nylon+MoS2), its performance is similar to nylon, but the use temperature is higher than nylon
DEVLON	-50~150°C -58~302°F	150~2500LB	Devlon is a polyamide with additives. This material covers a wide range of applications while having excellent wear properties, low friction, and improved impact strength.
PEEK	-100~260°C -148~500°F	150~2500LB	PEEK is a high performance engineered thermoplastic. It is excellent in water/chemical resistance and it is unaffected by continuous exposure to hot water/steam
Metal	As request	150~2500LB	Metal seat is usually used for high temperature, wear resistance, impact resistance, granular media conditions

Optional Seal Selections

Material	Operating Temperature	Operating Pressure	Description
EPDM	-46~150° C -50~302° F	150~600LB	EPDM is a type of synthetic rubber, have excellent chemical resistance to a variety of acids and alkalines, but can not resistant to petroleum conditions
NBR	-40~80° C -40~176° F	150~2500LB	NBR is typically resistant to mineral oil-based lubricants and greases, hydraulic fluids, hydrocarbons, and water.
HNBR	-40~80° C -40~176° F	150~2500LB	HNBR (Hydrogenated NBR) has similar media stability to NBR but with significantly better heat and oxidization stability.
HNBR AED	-40~80° C -40~176° F	600~2500LB	HNBR AED are typically used in high pressure applications encountered in the Oil and Gas industry.
VITON	-29~200° C -20~392° F	150~2500LB	VITON (fluorocarbon) is a fluorocarbon elastomer that is compatible with a broad range of chemicals, Viton offers excellent resistance to aggressive fuels and chemicals.
FVMQ	-60~177° C -76~351° F	150~2500LB	FVMQ is a silicone polymer chain, this material is far more resistant to oils and fuels than other silicones.

VALVE OPERATION/GEAR & ACTUATOR DETAILS

We Elite Flow Control Co. Ltd offered Handheld, Gear Box & Actuators as per client request and project requirements.

Gear Box Operated Valves

- It could be operated faster while the number of turns will increase.
- Where the torque needed would decrease through usage of reduction gear.

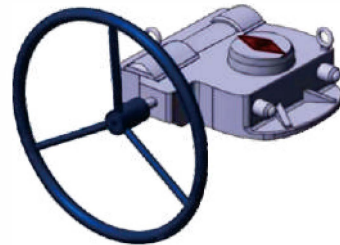

Combination of Electric Actuators & Gear Box Operated Valves

- It can be operated electrically, more labor-saving.
- Besides, it would be more economical than Electric Actuators but the operational time would increase.

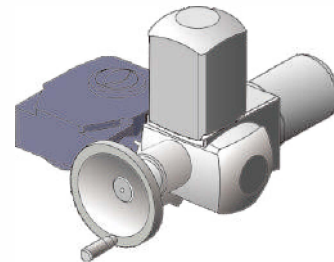

Electric Actuators For Valves

- The alternatives are to be used with electric actuation at various differential pressures.
- The remote & local control, lock hand control options are available.
- Ex-proof types are used at plants of Natural Gas, Crude Oil or Fuel.
- All actuators are protected as per IP67 or higher class.



Pneumatic Actuators For Valves

- Pneumatic control valve actuator converts energy (typically in the form of compressed air) into mechanical motion. The motion can be rotary or linear, depending on the type of actuator.
- Limit switches, Solenoid Valve and regulating filter accessories are delivered when required.
- Remote/Local controls, lockable and hand control options are available.



PAINTING & PACKING

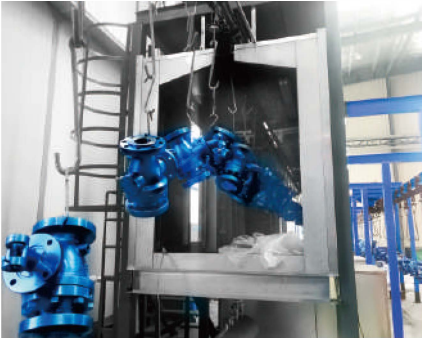

Painting



Painting



Painting

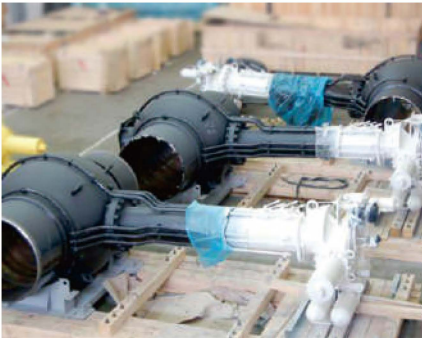

Packing



Packing



Packing



Packing



Packing



Packing



Packing Inspection



Final Packing Box



Final Packing Box



HOW TO AVOID PROBLEMS

How to Avoid Problems:

- Ball valves shall be transported and stored with the ball in the fully open position.
- Flanged ends and welded ends shall be protected.
- End protection shall be removed only when the valve is installed in the line.
- Valves shall be handled using the proper lifting lugs.
- Valves shall be stored according to Elite storage procedures. Long term storage shall be avoided.
- For welded-end valves, advise Elite if there will be a post weld heat treatment (transition pups may be necessary to avoid damages to seals).
- Flush and clean the line before operating the valve.
- Make sure no line-testing fluid is left in the line and/or the valve body.
- Avoid leaving the valve body filled with salt water to prevent internal corrosion.
- During line-testing, valves shall be left in the partially open position for the minimum possible amount of time.
- Standard ball valves shall be used for on-off service only. Throttling service (use of the valve with the ball partially open) can damage the seats.
- Make sure to take into consideration the actual service conditions when selecting materials for O-rings and seat inserts.
- Always specify anti-explosive decompression material for valves to be used in high pressure gas service.
- Make sure the selected actuator has been properly sized (an oversized actuator can be as dangerous as an undersized one).
- Advise Elite of cycle frequency to ensure proper sizing of actuator.
- Do not use the actuator to lift the valve

Warranty Clause:

Elite Flow Control products are delivered with a standard guarantee of good performance for the period of 18 months after the delivery date or 12 months of operation after commissioning.

WARNING: The scope of Warranty is covered for manufacturing defects only. In case the valve failure is due to the wrong operations by the customer the warranty is not applicable.

In order to claim the warranty due to the manufacturing defects, the customer needs to prepare the detailed rejection report including the inspection procedure, operational report, pictures of valves, if this report proves that the fault is due to the manufacturing defect, Elite will provide the appropriate solution.

"WE CONTROL THE FLOW"

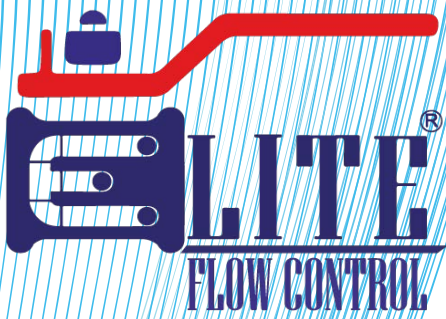

CHECK
VALVES

GLOBE
VALVES

PLUG
VALVES

GATE
VALVES



BUTTERFLY
VALVES

Wenzhou Elite Flow Control Co., Ltd.

Zhongou International Office Building,
Office No. 903, Yangguangdadao Street,
Oubei Town, Yongjia, Wenzhou City,
Zhejiang Province, China.



+86 (0) 577 66965398 | +44 (0) 7465 965031



+86-577-66965398



sales@elite-valves.com

Elite Flow Control UK Limited

Unit 1, Winghay Close,
Longbridge Hayes Industrial Estate,
Stoke-on-Trent, ST6 4DU,
Staffordshire, United Kingdom.

Elite Flow Control USA LLC

13220 Murphy Road,
Unit #100, Stafford TX 77477
+1 832-987-1774 / +1 832-539-6968

Factory

Puxi Village, Oubei Sub-
district, Yongjia, WenZhou,
Zhejiang, China.

www.elite-valves.com